

Instructions for Parts Books

The heading at the top of the page will be the same for the picture of the parts at it is for the page with the part numbers. B7100HST-D is 4WD model B7100HST-E is 2WD model

Definition of column headings on part number pages:

REF.No → The number referring to the part on the picture page of the parts book.

Part No. → The number assigned to this part at the time of printing the parts book.

Description → Discription of part.

Q'ty → Quantity of part used on that page.

S.No. → Serial number range of the equipment that this part will fit.

>= Your serial number should be greater than or equal to the number shown.

<= Your serial number should be lesser than or equal to the serial number shown.

I/C → Interchangeability of part shown.

↔ The part shown will work for the older and later serial number.

The part shown is not interchangeable with the other serial number.

← new for old

→ old for new

Remarks → Notes about this particulart part. Sometimes this may say except [FR] or [CA]

Note about Country Codes:

The parts books we use in the United States of America may also contain information about a part that would be different in another country. It is important that you are aware of the country codes in some instances.

Symbol	Country
A	United States of America
CA	Canada
FR	France
GR	Greece
PO	Portugal
AU	Australia

If the remarks column says for example EXCEPT [FR] this part works in all countries except France. That means it will work here in the USA.

ALL PRODUCT INDEX
B7100HST-D NEW TYPE

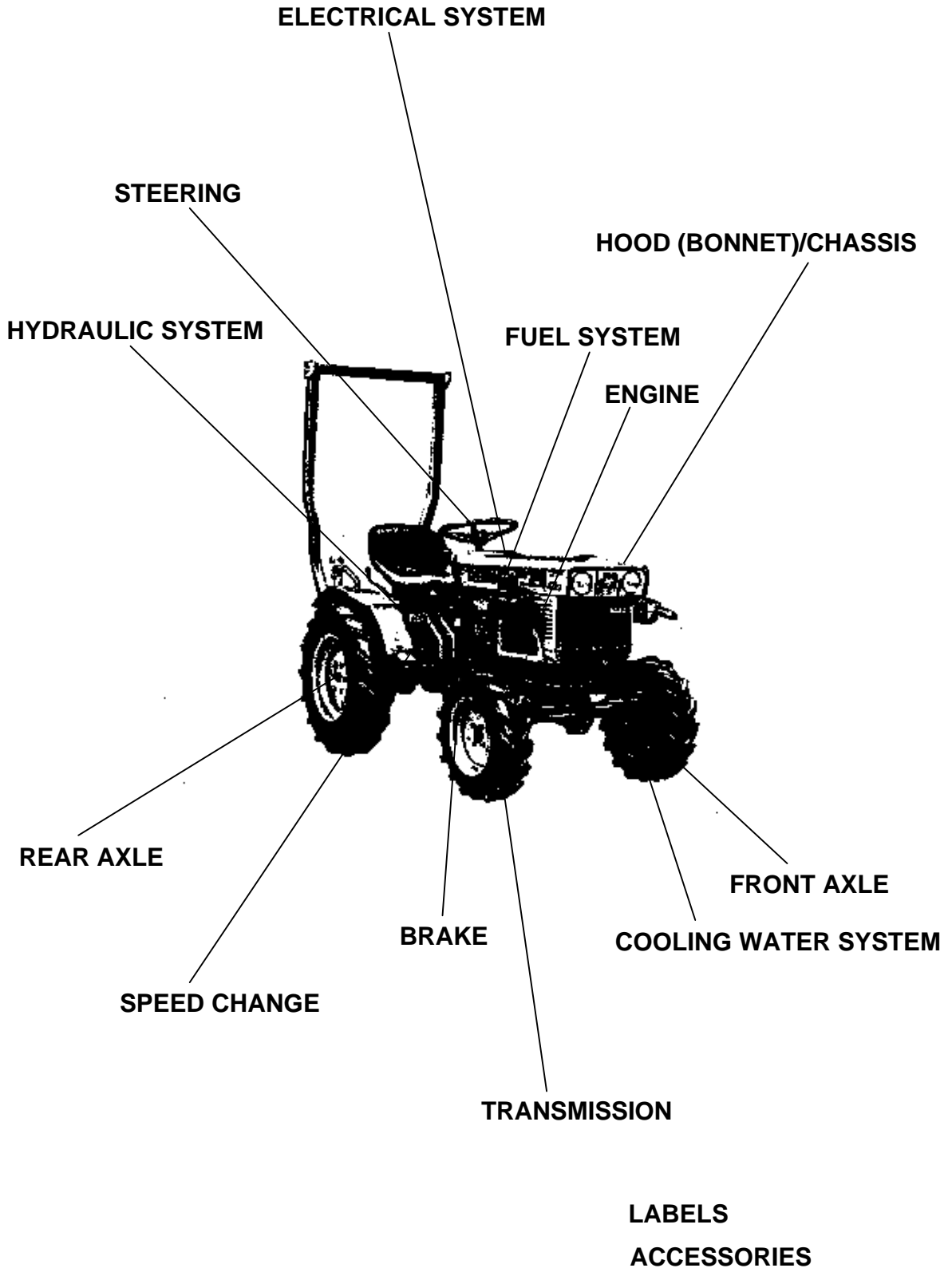

Item	Part No.	Description	Book	
ENGINE	01T01	CRANKCASE TRACTOR S.No.:B7100HST-D >=60164 B7100HST-E >=20025	100K0316	
	01T02	OIL PAN TRACTOR S.No.:B7100HST-D >=60164 B7100HST-E >=20025	100K0316	
	01T03	PISTON/CRANKSHAFT TRACTOR S.No.:B7100HST-D >=60164 B7100HST-E >=20025	100K0316	
	01T04	MAIN BEARING CASE TRACTOR S.No.:B7100HST-D >=60164 B7100HST-E >=20025	100K0316	
	01T05	FLYWHEEL TRACTOR S.No.:B7100HST-D >=60164 B7100HST-E >=20025	100K0316	
	01T06	CYLINDER HEAD TRACTOR S.No.:B7100HST-D >=60164 B7100HST-E >=20025	100K0316	
	01T07	VALVE/ROCKER ARM TRACTOR S.No.:B7100HST-D >=60164 B7100HST-E >=20025	100K0316	
	01T08	NOZZLE HOLDER TRACTOR S.No.:B7100HST-D >=60164 B7100HST-E >=20025	100K0316	
	01T09	NOZZLE HOLDER [COMPONENT PARTS] TRACTOR S.No.:B7100HST-D >=60164 B7100HST-E >=20025	100K0316	
	01T10	CYLINDER HEAD COVER TRACTOR S.No.:B7100HST-D >=60164 B7100HST-E >=20025	100K0316	
	01T11	INLET MANIFOLD TRACTOR S.No.:B7100HST-D >=60164 B7100HST-E >=20025	100K0316	
	01T13	EXHAUST MANIFOLD TRACTOR S.No.:B7100HST-D >=60164 B7100HST-E >=20025	100K0316	
	01T15	CAMSHAFT TRACTOR S.No.:B7100HST-D >=60164 B7100HST-E >=20025	100K0316	
	01T16	GEAR CASE TRACTOR S.No.:B7100HST-D >=60164 B7100HST-E >=20025	100K0316	
	01T17	FUEL PUMP TRACTOR S.No.:B7100HST-D >=60164 B7100HST-E >=20025	100K0316	
	01T18	INJECTION PUMP TRACTOR S.No.:B7100HST-D >=60164 B7100HST-E >=20025	100K0316	
	01T19	INJECTION PUMP [COMPONENT PARTS] TRACTOR S.No.:B7100HST-D >=60164 B7100HST-E >=20025	100K0316	
	01T20	SPEED CONTROL PLATE TRACTOR S.No.:B7100HST-D >=60164 B7100HST-E >=20025	100K0316	
	01T21	GOVERNOR TRACTOR S.No.:B7100HST-D >=60164 B7100HST-E >=20025	100K0316	
	01T22	UPPER GASKET KIT TRACTOR S.No.:B7100HST-D >=60164 B7100HST-E >=20025	100K0316	
	01T23	LOWER GASKET KIT TRACTOR S.No.:B7100HST-D >=60164 B7100HST-E >=20025	100K0316	
	ELECTRICAL SYSTEM	01T28	FAN/DYNAMO TRACTOR S.No.:B7100HST-D >=60164 B7100HST-E >=20025	100K0316
		01T29	DYNAMO [COMPONENT PARTS] TRACTOR S.No.:B7100HST-D >=60164 B7100HST-E >=20025	100K0316
	TRANSMISSION	01T35	CLUTCH TRACTOR S.No.:B7100HST-D >=60164 B7100HST-E >=20025	100K0316
HYDRAULIC SYSTEM	01T73	HYDRAULIC GEAR PUMP TRACTOR S.No.:B7100HST-D >=60164 B7100HST-E >=20025	100K0316	
	01T74	HYDRAULIC GEAR PUMP [COMPONENT PARTS] TRACTOR S.No.:B7100HST-D >=60164 B7100HST-E >=20025	100K0316	
LABELS	01T86	LABEL 1 TRACTOR S.No.:B7100HST-D >=60164 B7100HST-E >=20025	100K0316	
ENGINE	01T12	AIR CLEANER TRACTOR S.No.:B7100HST-D >=60164 B7100HST-E >=20025	100K0316	
	01T14	MUFFLER TRACTOR S.No.:B7100HST-D >=60164 B7100HST-E >=20025	100K0316	
	01T24	ACCELERATOR ROD TRACTOR S.No.:B7100HST-D >=60164 B7100HST-E >=20025	100K0316	

Item	Part No.	Description	Book	
FUEL SYSTEM	01T25	FUEL TANK/ACCELERATOR LEVER TRACTOR S.No.:B7100HST-D >=60164 B7100HST-E >=20025	100K0316	
	01T26	FUEL FILTER TRACTOR S.No.:B7100HST-D >=60164 B7100HST-E >=20025	100K0316	
COOLING WATER SYSTEM	01T27	RADIATOR/OIL COOLER TRACTOR S.No.:B7100HST-D >=60164 B7100HST-E >=20025	100K0316	
ELECTRICAL SYSTEM	01T30	STARTER TRACTOR S.No.:B7100HST-D >=60164 B7100HST-E >=20025	100K0316	
	01T31	STARTER [COMPONENT PARTS] TRACTOR S.No.:B7100HST-D >=60164 B7100HST-E >=20025	100K0316	
	01T32	BATTERY TRACTOR S.No.:B7100HST-D >=60164 B7100HST-E >=20025	100K0316	
	01T33	LIGHT TRACTOR S.No.:B7100HST-D >=60164 B7100HST-E >=20025	100K0316	
	01T34	PANEL TRACTOR S.No.:B7100HST-D >=60164 B7100HST-E >=20025	100K0316	
	TRANSMISSION	01T36	CLUTCH ROD TRACTOR S.No.:B7100HST-D >=60164 B7100HST-E >=20025	100K0316
		01T37	CLUTCH PEDAL TRACTOR S.No.:B7100HST-D >=60164 B7100HST-E >=20025	100K0316
01T38		CLUTCH HOUSING TRACTOR S.No.:B7100HST-D >=60164 B7100HST-E >=20025	100K0316	
01T39		TRANSMISSION CASE TRACTOR S.No.:B7100HST-D >=60164 B7100HST-E >=20025	100K0316	
01T40		PTO COVER TRACTOR S.No.:B7100HST-D >=60164 B7100HST-E >=20025	100K0316	
01T41		CASE COVER TRACTOR S.No.:B7100HST-D >=60164 B7100HST-E >=20025	100K0316	
01T42		HST TRACTOR S.No.:B7100HST-D >=60164 B7100HST-E >=20025	100K0316	
01T43		HST [COMPONENT PARTS] TRACTOR S.No.:B7100HST-D >=60164 B7100HST-E >=20025	100K0316	
01T44		PROPELLER SHAFT TRACTOR S.No.:B7100HST-D >=60164 B7100HST-E >=20025	100K0316	
01T45		2ND SHAFT TRACTOR S.No.:B7100HST-D >=60164 B7100HST-E >=20025	100K0316	
01T46		3RD SHAFT/5TH SHAFT TRACTOR S.No.:B7100HST-D >=60164 B7100HST-E >=20025	100K0316	
01T47		4TH SHAFT TRACTOR S.No.:B7100HST-D >=60164 B7100HST-E >=20025	100K0316	
01T48		FRONT WHEEL DRIVE SHAFT TRACTOR S.No.:B7100HST-D >=60164 B7100HST-E >=20025	100K0316	
01T4901		REAR PTO TRACTOR S.No.:B7100HST-D >=60164 B7100HST-E >=20025	100K0316	
01T4902		MID PTO TRACTOR S.No.:B7100HST-D >=60164 B7100HST-E >=20025	100K0316	
SPEED CHANGE		01T50	NEUTRAL HOLDER TRACTOR S.No.:B7100HST-D >=60164 B7100HST-E >=20025	100K0316
		01T51	SPEED CONTROL PEDAL TRACTOR S.No.:B7100HST-D >=60164 B7100HST-E >=20025	100K0316
	01T52	SPEED CHANGE PLATE TRACTOR S.No.:B7100HST-D >=60164 B7100HST-E >=20025	100K0316	
	01T53	HI-LO GEAR SHIFT LEVER TRACTOR S.No.:B7100HST-D >=60164 B7100HST-E >=20025	100K0316	
	01T54	PTO GEAR SHIFT LEVER TRACTOR S.No.:B7100HST-D >=60164 B7100HST-E >=20025	100K0316	
REAR AXLE	01T55	REAR DIFFERENTIAL TRACTOR S.No.:B7100HST-D >=60164 B7100HST-E >=20025	100K0316	
	01T56	REAR AXLE TRACTOR S.No.:B7100HST-D >=60164 B7100HST-E >=20025	100K0316	

Item	Part No.	Description	Book	
REAR AXLE	01T57	REAR AXLE CASE TRACTOR S.No.:B7100HST-D >=60164 B7100HST-E >=20025	100K0316	
	01T58	WHEEL HUB TRACTOR S.No.:B7100HST-D >=60164 B7100HST-E >=20025	100K0316	
BRAKE	01T59	BRAKE TRACTOR S.No.:B7100HST-D >=60164 B7100HST-E >=20025	100K0316	
	01T60	BRAKE ROD/PEDAL TRACTOR S.No.:B7100HST-D >=60164 B7100HST-E >=20025	100K0316	
FRONT AXLE	01T63	FRONT WHEEL HUB TRACTOR S.No.:B7100HST-D >=60164 B7100HST-E >=20025	100K0316	
	01T64	FRONT GEAR CASE TRACTOR S.No.:B7100HST-D >=60164 B7100HST-E >=20025	100K0316	
	01T65	BEVEL GEAR CASE TRACTOR S.No.:B7100HST-D >=60164 B7100HST-E >=20025	100K0316	
	01T66	FRONT AXLE ARM TRACTOR S.No.:B7100HST-D >=60164 B7100HST-E >=20025	100K0316	
	01T67	FRONT DIFFERENTIAL TRACTOR S.No.:B7100HST-D >=60164 B7100HST-E >=20025	100K0316	
	01T68	FRONT DRIVE SHAFT TRACTOR S.No.:B7100HST-D >=60164 B7100HST-E >=20025	100K0316	
	01T69	FRONT DRIVE LEVER TRACTOR S.No.:B7100HST-D >=60164 B7100HST-E >=20025	100K0316	
	01T70	FRONT WHEEL SUPPORT TRACTOR S.No.:B7100HST-D >=60164 B7100HST-E >=20025	100K0316	
	STEERING	01T71	KNUCKLE ARM TRACTOR S.No.:B7100HST-D >=60164 B7100HST-E >=20025	100K0316
		01T72	STEERING TRACTOR S.No.:B7100HST-D >=60164 B7100HST-E >=20025	100K0316
HYDRAULIC SYSTEM	01T75	HYDRAULIC PIPE 1 TRACTOR S.No.:B7100HST-D >=60164 B7100HST-E >=20025	100K0316	
	01T76	HYDRAULIC PIPE 2 TRACTOR S.No.:B7100HST-D >=60164 B7100HST-E >=20025	100K0316	
	01T77	LIFT ARM TRACTOR S.No.:B7100HST-D >=60164 B7100HST-E >=20025	100K0316	
	01T78	HYD.CYLINDER CAP TRACTOR S.No.:B7100HST-D >=60164 B7100HST-E >=20025	100K0316	
	01T79	CONTROL VALVE TRACTOR S.No.:B7100HST-D >=60164 B7100HST-E >=20025	100K0316	
	01T80	CONTROL VALVE [COMPONENT PARTS] TRACTOR S.No.:B7100HST-D >=60164 B7100HST-E >=20025	100K0316	
	01T81	3-POINT LINKAGE TRACTOR S.No.:B7100HST-D >=60164 B7100HST-E >=20025	100K0316	
HOOD (BONNET)/CHASSIS	01T82	HOOD TRACTOR S.No.:B7100HST-D >=60164 B7100HST-E >=20025	100K0316	
	01T83	FENDER TRACTOR S.No.:B7100HST-D >=60164 B7100HST-E >=20025	100K0316	
	01T84	SEAT TRACTOR S.No.:B7100HST-D >=60164 B7100HST-E >=20025	100K0316	
	01T85	STEP TRACTOR S.No.:B7100HST-D >=60164 B7100HST-E >=20025	100K0316	
LABELS	01T87	LABEL 2 TRACTOR S.No.:B7100HST-D >=60164 B7100HST-E >=20025	100K0316	
ACCESSORIES	01T88	ACCESSORIES AND SERVICE PARTS TRACTOR S.No.:B7100HST-D >=60164 B7100HST-E >=20025	100K0316	

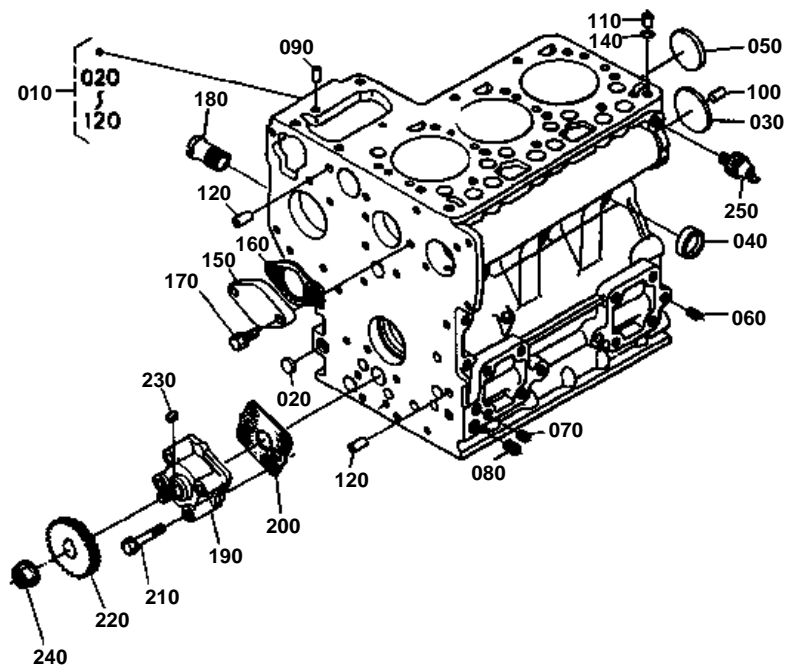

15372-004-10

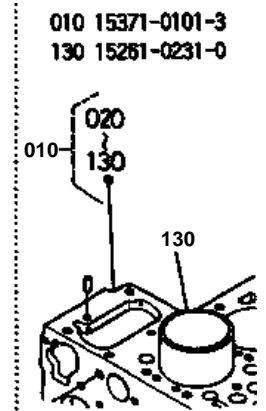



↔ Interchangeable; ≠ not interchangeable; ← new for old; → old for new

REF.No	Part No.	Description	Q'ty	S.No.	I/C	REMARKS	Weight (kgf)	Weight (lb)
010	15371-01013	COMP.CRANKCASE	1	<=755814			0	0
010	15973-01012	COMP.CRANKCASE	1	>=755815	≠		31	68.2
020	15261-96170	PLUG	3				0.005	0.011
030	15261-96160	PLUG	1				0.02	0.044
040	15321-96260	CAP SEALING	5				0.014	0.0308
050	15221-03490	CAP SEALING	1				0.02	0.044
060	15261-96010	PLUG	6				0.002	0.0044
070	15521-96020	PLUG	3				0.003	0.0066
080	15521-96030	PLUG	1				0.007	0.0154
090	05012-00609	PIN STRAIGHT	2				0.003	0.0066
100	05012-00814	PIN STRAIGHT	2				0.006	0.0132
110	15221-33650	PIN PIPE	1				0.004	0.0088
120	15231-33960	PIN PIPE	2				0.001	0.0022
130	15261-02310	LINER CYLINDER	3	<=755814			0.376	0.8272
140	15221-33700	O RING	1				0.001	0.0022
150	15261-73910	COVER WATER	1				0.13	0.286
160	15261-73920	GASKET WATER COVER	1				0	0
170	01023-50618	BOLT	2				0.006	0.0132
180	15221-72880	PIPE WATER	1				0.115	0.253
190	15261-35010	ASSY PUMP OIL	1				0.32	0.704
200	15261-35150	GASKET OIL PUMP	1				0	0
210	15261-91022	BOLT	4				0.012	0.0264
220	15954-35662	GEAR OIL PUMP DRIVE	1				0.14	0.308
230	05712-00410	KEY FEATHER	1				0.001	0.0022
240	02771-50100	NUT FLANGE	1				0	0
250	15841-39010	SWITCH OIL	1				0.03	0.066

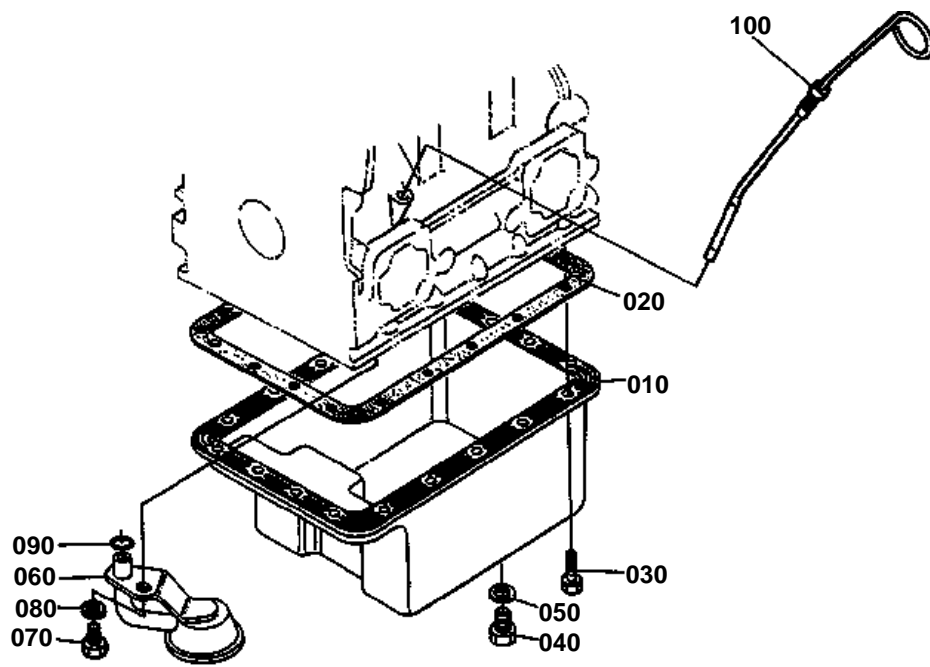

15372-002-10



↔ Interchangeable; ≠ not interchangeable; ← new for old; → old for new

REF.No	Part No.	Description	Q'ty	S.No.	I/C	REMARKS	Weight (kgf)	Weight (lb)
010	15371-01614	OIL PAN	1				1.1	2.42
020	15381-01620	GASKET OIL PAN	1				0	0
030	15381-91092	BOLT	18				0.002	0.0044
040	15221-33750	PLUG	1				0.032	0.0704
050	15109-33660	GASKET	1				0.001	0.0022
060	15371-32110	FILTER OIL	1				0.4	0.88
070	01153-50816	BOLT	1				0.01	0.022
080	04512-50080	WASHER SPRING	1				0.001	0.0022
090	04810-00140	O RING	1				0.001	0.0022
100	15371-36410	GAUGE OIL	1				0.021	0.0462

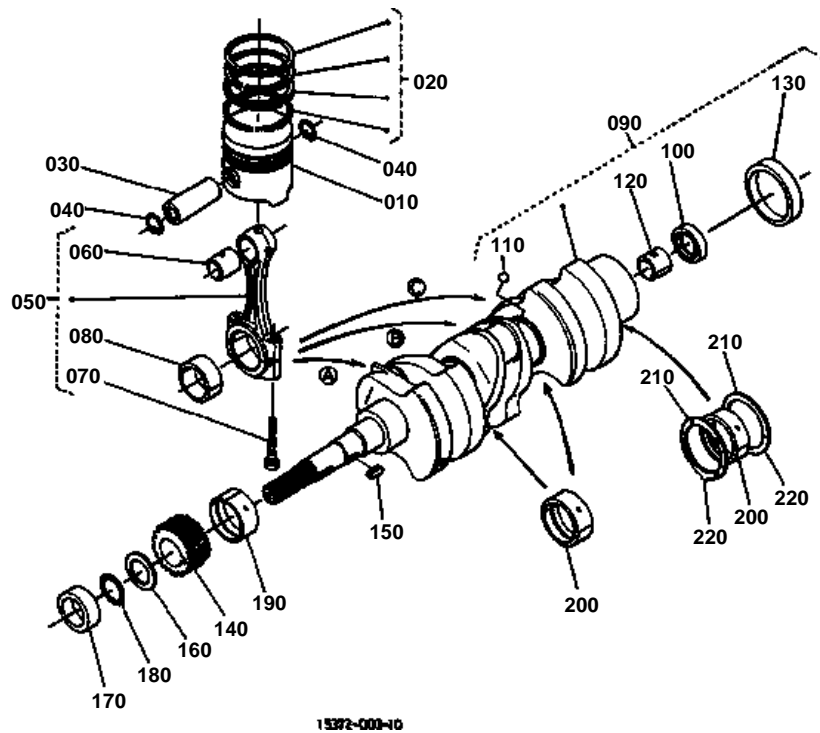



↔ Interchangeable; ≠ not interchangeable; ← new for old; → old for new

REF.No	Part No.	Description	Q'ty	S.No.	I/C	REMARKS	Weight (kgf)	Weight (lb)
010	15261-21110	PISTON	3			STD	0.304	0.6688
010	15261-21910	PISTON	3			+0.50MM	0.3	0.66
020	15271-21050	ASSY PISTON RING	3			STD	0.026	0.0572
020	15271-21090	ASSY PISTON RING	3			+0.50MM	0.04	0.088
030	15261-21310	PIN PISTON	3				0.102	0.2244
040	15261-21330	CIR CLIP PISTON PIN	6				0.001	0.0022
050	15694-22010	ASSY CONNECTING ROD	3				0.5	1.1
060	15261-21980	BUSH PISTON PIN	3				0.012	0.0264
070	15381-22140	BOLT CONNECTING ROD	6				0.02	0.044
080	15694-22310	METAL CRANKPIN	3			SET STD	0.02	0.044
080	15694-22970	METAL CRANKPIN	3			SET -0.20MM	0.025	0.055
080	15694-22980	METAL CRANKPIN	3			SET -0.40MM	0.02	0.044
090	15532-23010	COMP.CRANKSHAFT	1				8	17.6
100	09400-14247	SEAL OIL	1				0.004	0.0088
110	07715-03207	BALL	3				0.001	0.0022
120	66621-14120	BEARING DRY	1				0.006	0.0132
130	19215-23280	SLEEVE CRANKSHAFT	1				0.05	0.11
140	15261-24110	GEAR CRANKSHAFT	1				0.164	0.3608
150	05712-00515	KEY FEATHER	1				0.003	0.0066
160	15261-23310	SLINGER OIL	1				0.008	0.0176
170	15532-23250	COLLAR CRANKSHAFT	1				0.029	0.0638
180	04811-10220	O RING	1				0.001	0.0022
190	15694-23470	METAL CRANKSHAFT	1			STD	0.035	0.077
190	15694-23910	METAL CRANKSHAFT	1			-0.20MM	0.04	0.088
190	15694-23920	METAL CRANKSHAFT	1			-0.40MM	0.045	0.099
200	15694-23480	METAL CRANKSHAFT	3			SET STD	0.04	0.088
200	15694-23930	METAL CRANKSHAFT	3			SET -0.20MM	0.05	0.11
200	15694-23940	METAL CRANKSHAFT	3			SET -0.40MM	0.046	0.1012
210	15261-23530	METAL SIDE	2			STD	0.006	0.0132
210	15261-23950	METAL SIDE	2			+0.20MM	0.006	0.0132
210	15261-23960	METAL SIDE	2			+0.40MM	0.007	0.0154
220	15261-23540	METAL SIDE	2			STD	0.007	0.0154
220	15261-23970	METAL SIDE	2			+0.20MM	0.006	0.0132
220	15261-23980	METAL SIDE	2			+0.40MM	0.007	0.0154

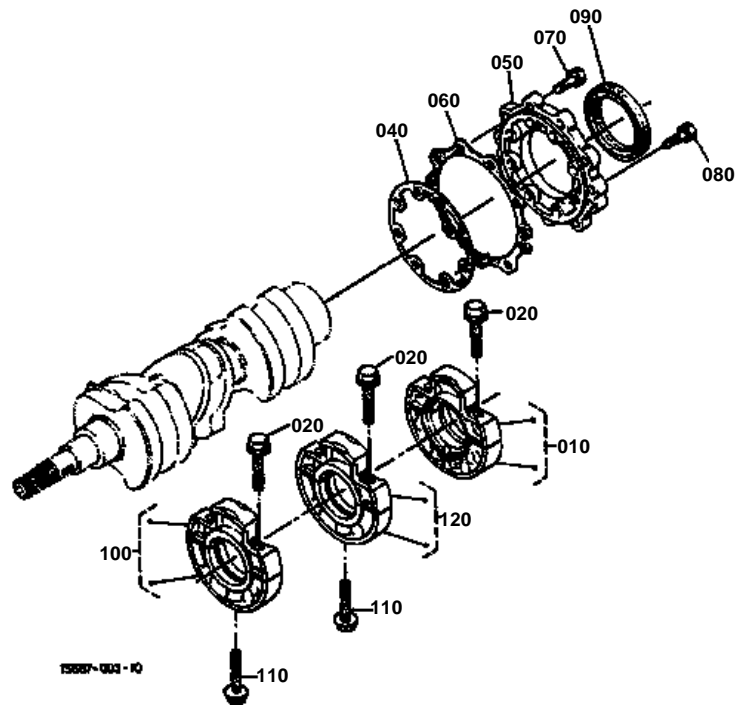



↔ Interchangeable; ≠ not interchangeable; ← new for old; → old for new

REF.No	Part No.	Description	Q'ty	S.No.	I/C	REMARKS	Weight (kgf)	Weight (lb)
010	15261-04090	ASSY CASE MAIN BRG.	1				0.8	1.76
020	15381-04540	BOLT BEARING CASE	6				0.02	0.044
030	99999-99999	BLANK	0				0	0
040	15261-04360	GASKET BRG.CASE	1				0	0
050	15549-04810	COVER BEARING CASE	1				0.2	0.44
060	15261-04820	GASKET BRG.CASE COV.	1				0	0
070	01023-50620	BOLT	9				0.006	0.0132
080	01023-50625	BOLT	8				0.007	0.0154
090	19215-04460	SEAL OIL	1				0.03	0.066
100	15261-04040	ASSY CASE MAIN BRG.	1				0.687	1.5114
110	15381-04560	BOLT BEARING CASE	2				0.02	0.044
120	15381-04050	ASSY CASE MAIN BRG.	1				0.688	1.5136

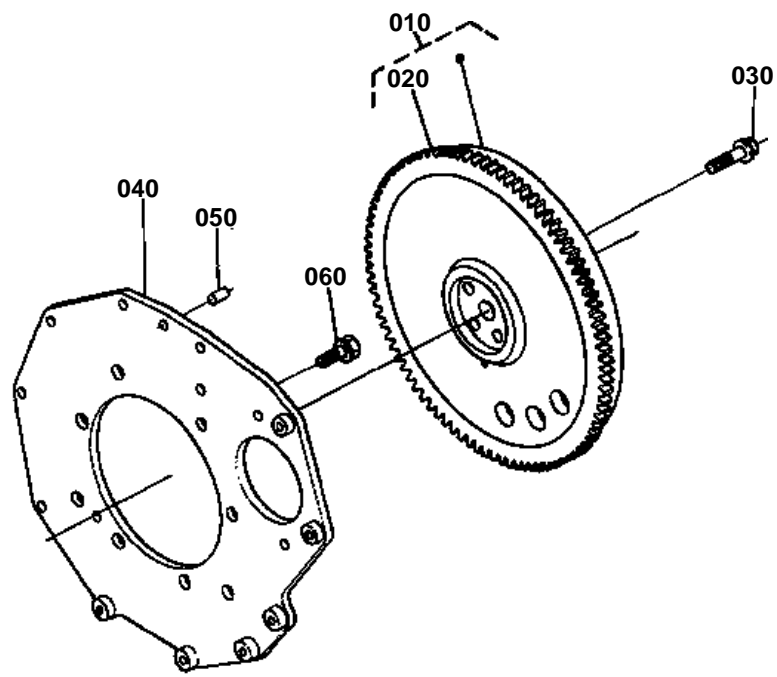

15372-004-10



↔ Interchangeable; ≠ not interchangeable; ← new for old; → old for new

REF.No	Part No.	Description	Q'ty	S.No.	I/C	REMARKS	Weight (kgf)	Weight (lb)
010	15375-25012	COMP.FLYWHEEL	1				11	24.2
020	15262-63820	GEAR RING	1				0.65	1.43
030	15533-25162	BOLT FLYWHEEL	5				0.03	0.066
040	15261-04620	PLATE REAR END	1				2.71	5.962
050	05012-00814	PIN STRAIGHT	1				0.006	0.0132
060	15261-91190	BOLT	8				0.03	0.066

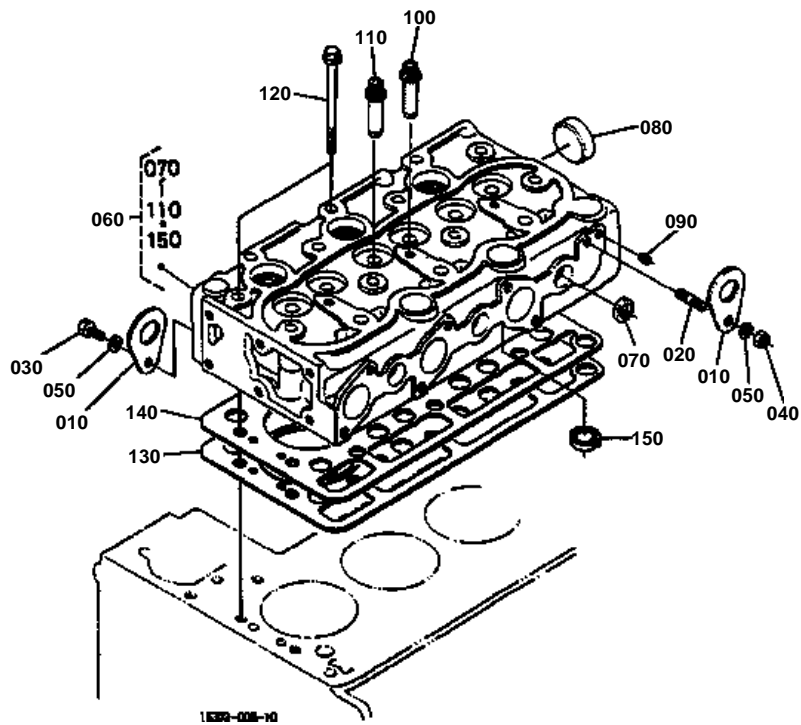



↔ Interchangeable; ≠ not interchangeable; ← new for old; → old for new

REF.No	Part No.	Description	Q'ty	S.No.	I/C	REMARKS	Weight (kgf)	Weight (lb)
010	15221-01750	HOOK ENGINE	2				0.04	0.088
020	01513-50816	STUD	1				0.009	0.0198
030	01153-50816	BOLT	1				0.01	0.022
040	02156-50080	NUT	1				0.004	0.0088
050	04512-50080	WASHER SPRING	2				0.001	0.0022
060	15371-03047	COMP.CYLINDER HEAD	1				9.2	20.24
070	15261-03370	CAP SEALING	5				0.005	0.011
080	15321-96260	CAP SEALING	1				0.014	0.0308
090	15261-96010	PLUG	2				0.002	0.0044
100	15261-13540	GUIDE INLET VALVE	3				0.02	0.044
110	15261-13560	GUIDE EXHAUST VALVE	3				0.02	0.044
120	19215-03450	BOLT CYLINDER HEAD	14				0.047	0.1034
130	15371-03312	GASKET CYLINDER HEAD	1				0	0
140	15371-03322	SHIM CYL.HEAD GASKET	1				0.029	0.0638
150	15261-03140	COMBUSTION CHAMBER	3				0.023	0.0506

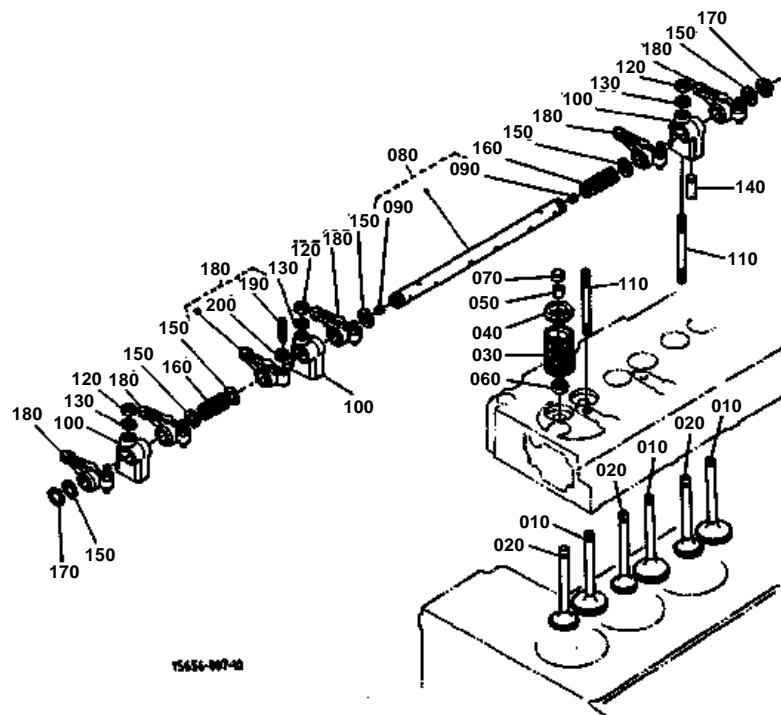



↔ Interchangeable; ≠ not interchangeable; ← new for old; → old for new

REF.No	Part No.	Description	Q'ty	S.No.	I/C	REMARKS	Weight (kgf)	Weight (lb)
010	15261-13110	VALVE INLET	3				0.043	0.0946
020	15261-13120	VALVE EXHAUST	3				0.038	0.0836
030	15261-13240	SPRING VALVE	6				0.02	0.044
040	16241-13330	RETAINER VALVE SP.	6				0.012	0.0264
050	15261-13360	COLLET VALVE SPRING	6			SET	0.004	0.0088
060	15261-13150	SEAL VALVE STEM	6				0.001	0.0022
070	15261-13280	CAP VALVE	6	<=821125			0	0
070	16241-13280	CAP VALVE	6	>=821126	↔		0.005	0.011
080	15371-14050	ASSY SHAFT R-ARM	1				0.133	0.2926
090	03410-50606	SCREW SET	2				0.001	0.0022
100	15261-14350	BRACKET ROCKER ARM	3				0.032	0.0704
110	15952-14410	STUD	3				0	0
120	15261-92010	NUT	3				0.005	0.011
130	15261-94010	WASHER PLAIN	3				0.002	0.0044
140	15261-14420	SCREW SET.ROCKER ARM	1				0.002	0.0044
150	15261-14430	WASHER R-ARM.SHAFT	6				0.001	0.0022
160	15261-14310	SPRING ROCKER ARM	2				0.003	0.0066
170	04612-00110	CIR CLIP EXTERNAL	2				0.001	0.0022
180	15381-14030	ASSY ROCKER ARM	6	<=778923			0.05	0.11
180	15382-14030	ASSY ROCKER ARM	6	>=778924	→		0.05	0.11
190	15261-14232	SCREW ADJUSTING	6				0.006	0.0132
200	15261-14240	NUT	6				0.002	0.0044

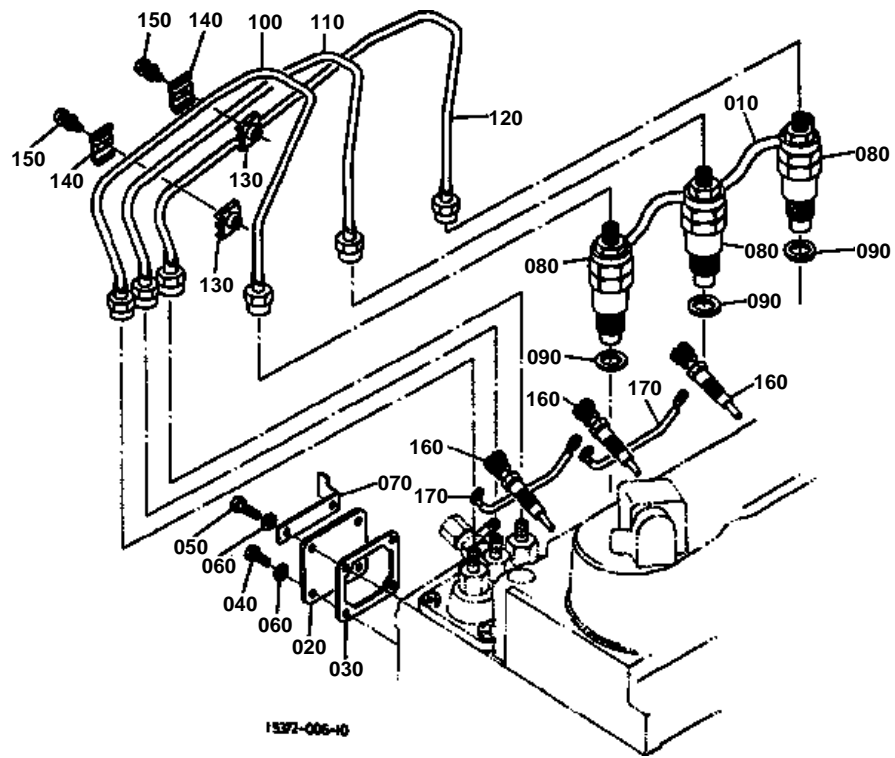



↔ Interchangeable; ≠ not interchangeable; ← new for old; → old for new

REF.No	Part No.	Description	Q'ty	S.No.	I/C	REMARKS	Weight (kgf)	Weight (lb)
010	15371-42502	ASSY PIPE OVER FLOW	1				0.065	0.143
020	15241-51650	COVER INJECTION PUMP	1				0.082	0.1804
030	15231-05130	GASKET BREATHER	1				0	0
040	01053-50614	BOLT	2				0.005	0.011
050	01053-50616	BOLT	2				0.005	0.011
060	04512-50060	WASHER SPRING	4				0	0
070	66711-43290	SUPPORT RELEASE ROD	1				0.039	0.0858
080	15261-53020	ASSY HOLDER NOZZLE	3	<=821125		REFER TO L.No.0B05-R0 FOR COMPONENTS.	0	0
080	19202-53020	ASSY HOLDER NOZZLE	3	>=821126	↔	REFER TO L.No.0B05-R0 FOR COMPONENTS.	0.25	0.55
090	17011-53620	GASKET	3				0.003	0.0066
100	15261-53710	PIPE INJECTION	1				0.103	0.2266
110	15261-53720	PIPE INJECTION	1				0.1	0.22
120	15381-53730	PIPE INJECTION	1				0.102	0.2244
130	15841-53850	CLAMP PIPE	2				0.01	0.022
140	15841-53860	CLAMP PIPE	2				0.009	0.0198
150	03024-50520	SCREW WITH WASHER	2				0.004	0.0088
160	15261-65510	PLUG GLOW	3				0.03	0.066
170	15261-65560	CORD GLOW PLUG	2				0.005	0.011

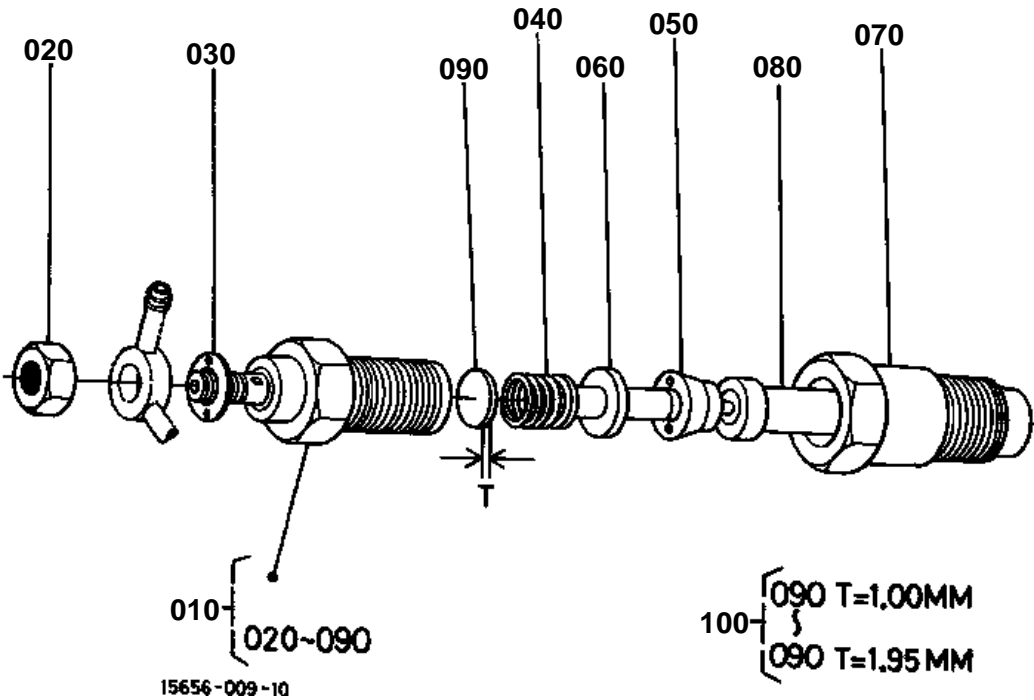



**NOZZLE HOLDER [COMPONENT PARTS] TRACTOR S.No.:B7100HST-D >=60164
B7100HST-E >=20025**

↔ Interchangeable; ≠ not interchangeable; ← new for old; → old for new

REF.No	Part No.	Description	Q'ty	S.No.	I/C	REMARKS	Weight (kgf)	Weight (lb)
010	15261-53020	ASSY HOLDER NOZZLE	3	≤821125			0	0
010	19202-53020	ASSY HOLDER NOZZLE	3	≥821126	↔		0.25	0.55
020	15221-92020	NUT	3				0.011	0.0242
030	15221-94020	WASHER PLAIN	3				0.002	0.0044
040	15221-53170	SPRING NOZZLE	3				0.01	0.022
050	15221-53350	PIECE DISTANCE	3				0.016	0.0352
060	15221-53160	PUSH ROD	3				0.003	0.0066
070	15221-53280	NUT NOZZLE	3				0.068	0.1496
080	15021-53610	PIECE NOZZLE	3	≤821125			0	0
080	19202-53610	PIECE NOZZLE	3	≥821126	↔		0.045	0.099
090	15221-98110	WASHER ADJUSTING	3			1.00MM	0.001	0.0022
090	15221-98120	WASHER ADJUSTING	3			1.05MM	0.001	0.0022
090	15221-98130	WASHER ADJUSTING	3			1.10MM	0.001	0.0022
090	15221-98140	WASHER ADJUSTING	3			1.15MM	0.001	0.0022
090	15221-98150	WASHER ADJUSTING	3			1.20MM	0.001	0.0022
090	15221-98160	WASHER ADJUSTING	3			1.25MM	0.001	0.0022
090	15221-98170	WASHER ADJUSTING	3			1.30MM	0.001	0.0022
090	15221-98180	WASHER ADJUSTING	3			1.35MM	0.001	0.0022
090	15221-98190	WASHER ADJUSTING	3			1.40MM	0.002	0.0044
090	15221-98200	WASHER ADJUSTING	3			1.45MM	0.001	0.0022
090	15221-98210	WASHER ADJUSTING	3			1.50MM	0.001	0.0022
090	15221-98220	WASHER ADJUSTING	3			1.55MM	0.003	0.0066
090	15221-98230	WASHER ADJUSTING	3			1.60MM	0.003	0.0066
090	15221-98240	WASHER ADJUSTING	3			1.65MM	0.002	0.0044
090	15221-98250	WASHER ADJUSTING	3			1.70MM	0.002	0.0044
090	15221-98260	WASHER ADJUSTING	3			1.75MM	0.002	0.0044
090	15221-98270	WASHER ADJUSTING	3			1.80MM	0.002	0.0044
090	15221-98280	WASHER ADJUSTING	3			1.85MM	0.002	0.0044
090	15221-98290	WASHER ADJUSTING	3			1.90MM	0.002	0.0044
090	15221-98300	WASHER ADJUSTING	3			1.95MM	0.003	0.0066
100	15221-98100	ASSY WASHER ADJUST	3				0.03	0.066

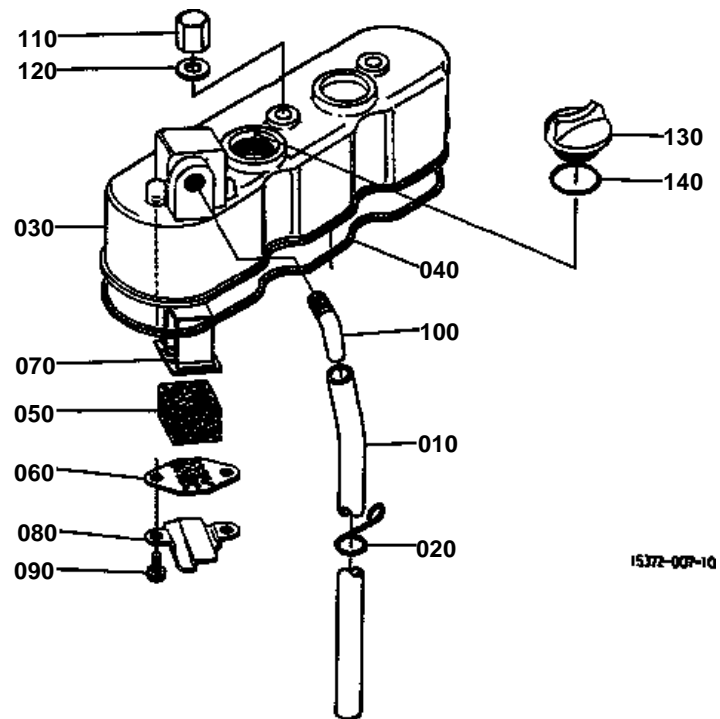



CYLINDER HEAD COVER TRACTOR S.No.:B7100HST-D >=60164 B7100HST-E >=20025

↔ Interchangeable; ≠ not interchangeable; ← new for old; → old for new

REF.No	Part No.	Description	Q'ty	S.No.	I/C	REMARKS	Weight (kgf)	Weight (lb)
010	15261-05510	PIPE BREATHER	1				0.069	0.1518
020	15951-05590	CLAMP PIPE	1				0.003	0.0066
030	15534-14510	COVER CYL.HEAD	1				0.6	1.32
040	15381-14520	GASKET HEAD COVER	1				0.005	0.011
050	15521-05670	ELEMENT BREATHER	1				0.01	0.022
060	15951-05140	PLATE B/THER ELEMENT	1				0.005	0.011
070	15521-05150	PLATE B/THER ELEMENT	1				0.01	0.022
080	15951-05370	OIL SHIELD BREATHER	1				0.005	0.011
090	03024-50510	SCREW WITH WASHER	2				0.002	0.0044
100	15521-05550	JOINT BREATHER PIPE	1				0.04	0.088
110	15952-92330	NUT CAP	3				0.01	0.022
120	15951-96660	GASKET	3				0.001	0.0022
130	15221-33140	PLUG OIL FILLER	1	<=834110			0.038	0.0836
130	15852-33140	PLUG OIL FILLER	1	>=834111	↔		0.038	0.0836
140	04811-50300	O RING	1				0.001	0.0022

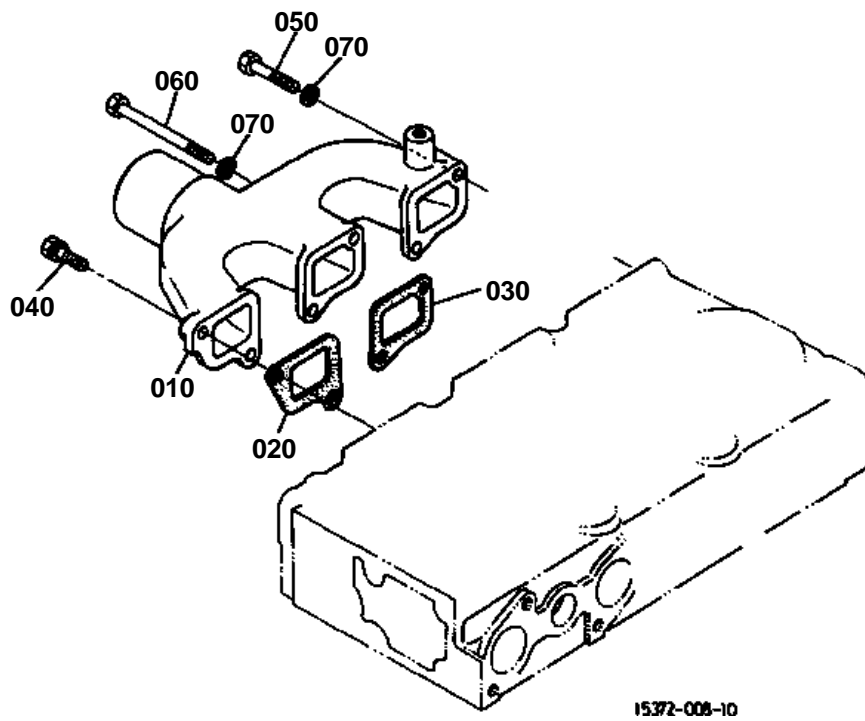



↔ Interchangeable; ≠ not interchangeable; ← new for old; → old for new

REF.No	Part No.	Description	Q'ty	S.No.	I/C	REMARKS	Weight (kgf)	Weight (lb)
010	15371-11760	MANIFOLD INLET	1				0.45	0.99
020	15261-11820	GASKET IN-MANIFOLD	1				0	0
030	15261-11830	GASKET IN-MANIFOLD	2				0	0
040	01023-50620	BOLT	4				0.006	0.0132
050	01053-50660	BOLT	1				0.014	0.0308
060	15381-91070	BOLT	1				0.016	0.0352
070	04512-50060	WASHER SPRING	2				0	0

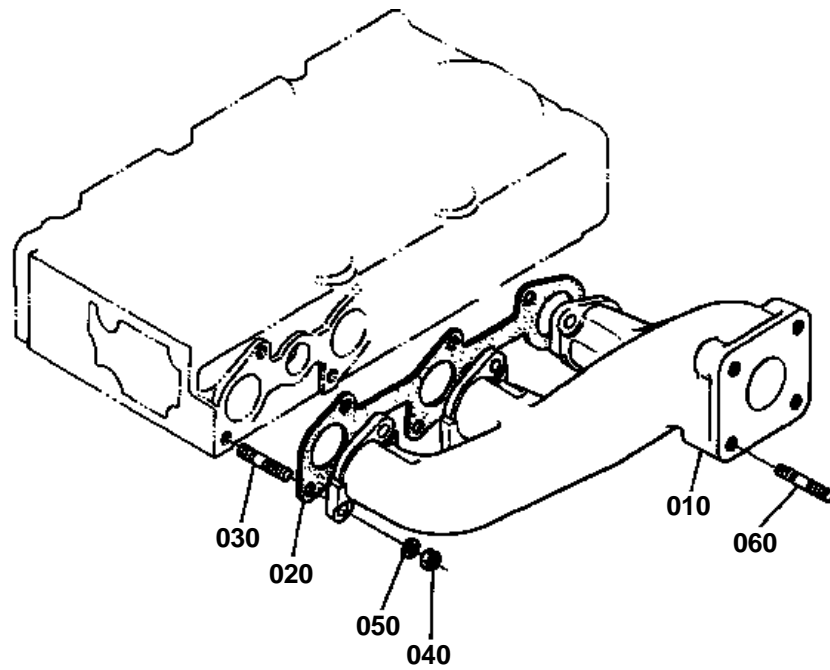

15372-009-10



↔ Interchangeable; ≠ not interchangeable; ← new for old; → old for new

REF.No	Part No.	Description	Q'ty	S.No.	I/C	REMARKS	Weight (kgf)	Weight (lb)
010	15371-12310	MANIFOLD EXHAUST	1				1.77	3.894
020	15381-12360	GASKET EX-MANIFOLD	1				0	0
030	15381-91532	STUD	6				0.005	0.011
040	02056-50060	NUT	6				0.002	0.0044
050	04512-50060	WASHER SPRING	6				0	0
060	01513-50822	STUD	4				0.01	0.022

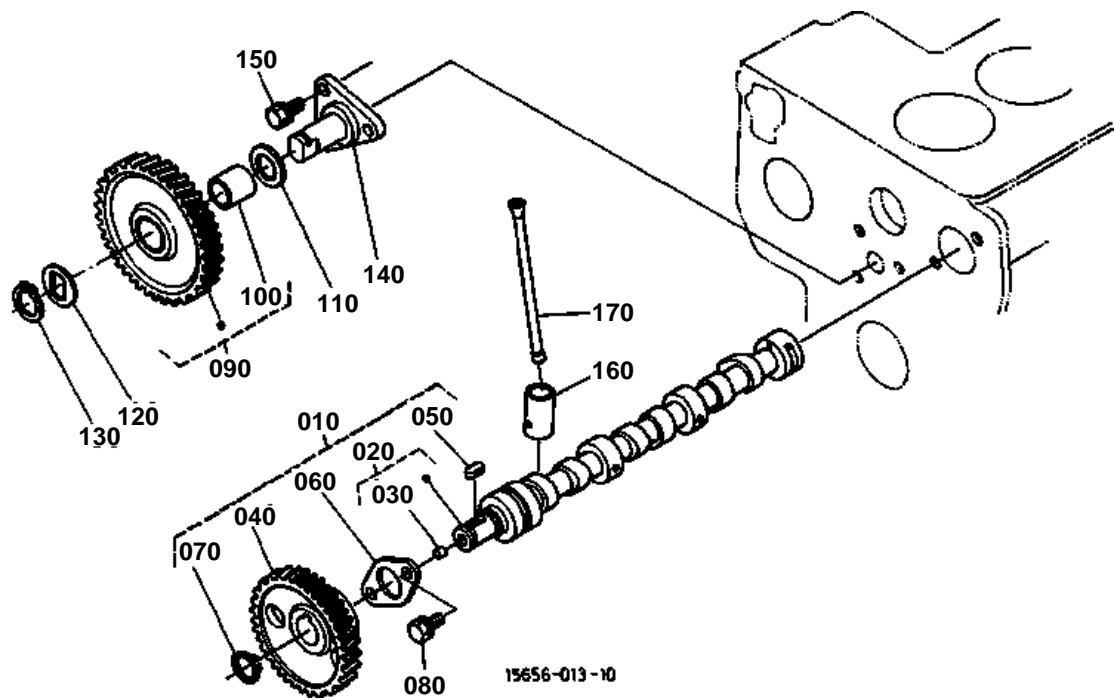



↔ Interchangeable; ≠ not interchangeable; ← new for old; → old for new

REF.No	Part No.	Description	Q'ty	S.No.	I/C	REMARKS	Weight (kgf)	Weight (lb)
010	15381-16010	ASSY CAMSHAFT	1				1.045	2.299
020	15381-16110	COMP. CAMSHAFT	1				0.965	2.123
030	15261-96880	PLUG BLIND	2				0.002	0.0044
040	15261-16510	GEAR CAMSHAFT	1				0.354	0.7788
050	05712-00515	KEY FEATHER	1				0.003	0.0066
060	15261-16270	STOPPER CAMSHAFT	1				0.034	0.0748
070	04612-00180	CIR CLIP EXTERNAL	1				0.001	0.0022
080	01023-50614	BOLT	2				0.005	0.011
090	15741-24010	COMP.GEAR IDLE	1				0.64	1.408
100	15741-24980	BUSH IDLE GEAR	1				0.03	0.066
110	15741-24360	COLLAR IDLE GEAR	1				0.04	0.088
120	15741-24370	COLLAR IDLE GEAR	1				0.015	0.033
130	15741-24320	CIR CLIP IDLE GEAR	1				0.01	0.022
140	15741-24250	SHAFT IDLE GEAR	1				0.35	0.77
150	01023-50616	BOLT	3				0.005	0.011
160	15261-15550	TAPPET	6				0.03	0.066
170	15261-15110	PUSH ROD	6				0.022	0.0484

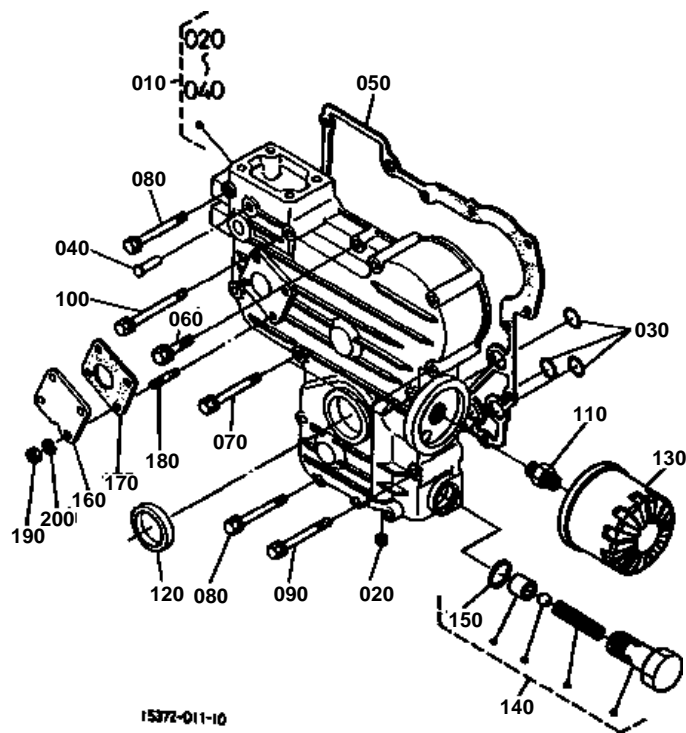



↔ Interchangeable; ≠ not interchangeable; ← new for old; → old for new

REF.No	Part No.	Description	Q'ty	S.No.	I/C	REMARKS	Weight (kgf)	Weight (lb)
010	15381-04025	COMP.CASE GEAR	1				1.6	3.52
020	15261-96020	PLUG	2	<=775308			0	0
020	16851-96010	PLUG	2	>=775309	↔		0.015	0.033
030	04811-06130	O RING	3				0.001	0.0022
040	15221-56280	PIN START SPRING	1				0.006	0.0132
050	15261-04132	GASKET GEAR CASE	1				0	0
060	01023-50630	BOLT	1				0.008	0.0176
070	01023-50660	BOLT	3				0.01	0.022
080	01023-50665	BOLT	8				0.015	0.033
090	01023-50670	BOLT	1				0	0
100	01023-50675	BOLT	1				0.01	0.022
110	15241-32290	JOINT PIPE	1				0.053	0.1166
120	09550-00008	SEAL OIL	1				0.01	0.022
130	15241-32090	ASSY FILTER	1				0.35	0.77
140	15261-36070	ASSY VALVE RELIEF	1				0.078	0.1716
150	04810-00150	O RING	1				0.001	0.0022
160	15223-83340	COVER	1				0.152	0.3344
170	15221-88130	GASKET H/METER UNIT	1				0	0
180	15221-88210	STUD	4				0.005	0.011
190	02056-50060	NUT	4				0.002	0.0044
200	04512-50060	WASHER SPRING	4				0	0

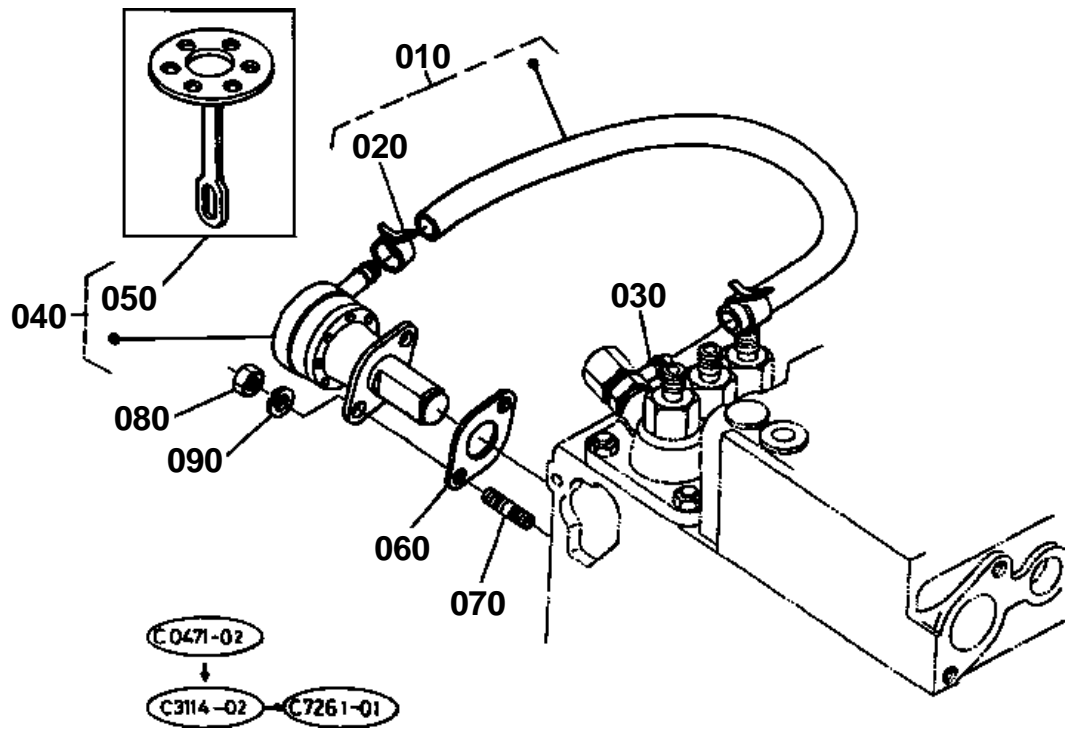



↔ Interchangeable; ≠ not interchangeable; ← new for old; → old for new

REF.No	Part No.	Description	Q'ty	S.No.	I/C	REMARKS	Weight (kgf)	Weight (lb)
010	15261-42010	ASSY PIPE FUEL	1				0.032	0.0704
020	16241-42750	BAND PIPE	2				0	0
030	14111-42410	JOINT EYE	1				0.025	0.055
040	15381-52030	ASSY PUMP FUEL	1				0	0
050	15381-52040	COMP.DIAPHRAGM	1				0	0
060	15241-52140	GASKET FUEL PUMP	1				0	0
070	01513-50616	STUD	2				0.004	0.0088
080	02056-50060	NUT	2				0.002	0.0044
090	04512-50060	WASHER SPRING	2				0	0

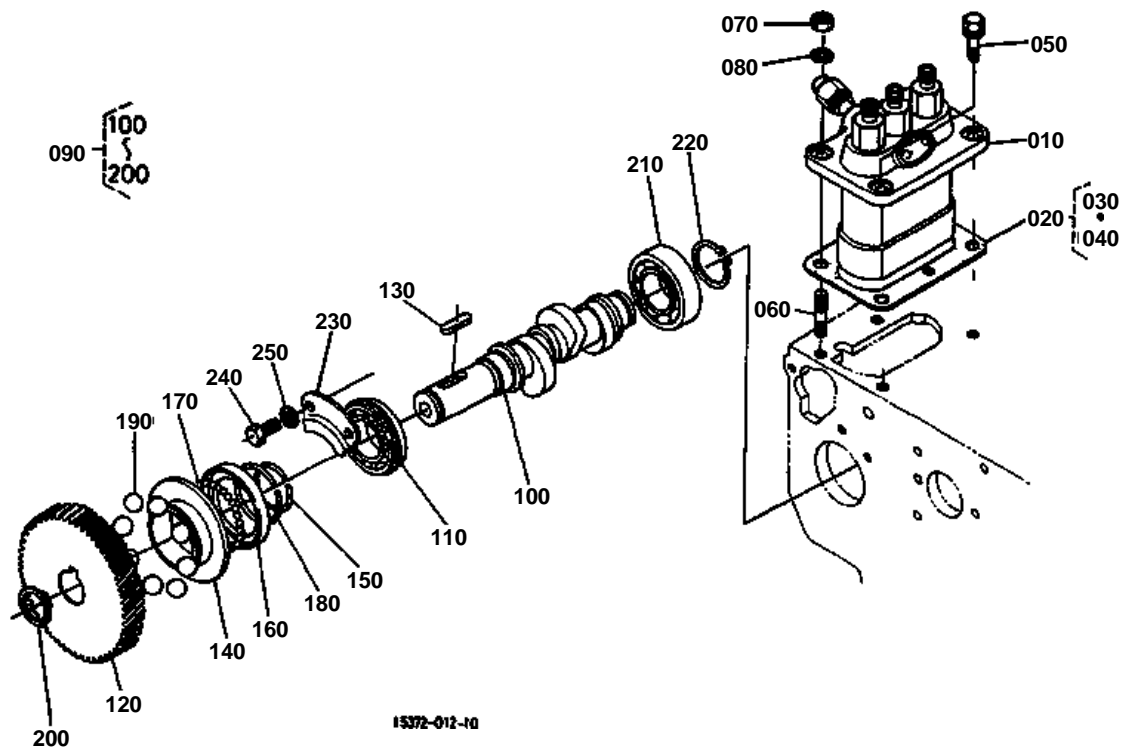



↔ Interchangeable; ≠ not interchangeable; ← new for old; → old for new

REF.No	Part No.	Description	Q'ty	S.No.	I/C	REMARKS	Weight (kgf)	Weight (lb)
010	15381-51010	ASSY PUMP INJECTION	1			REFER TO L.No.0B11-L0 FOR COMPONENTS.	2.16	4.752
020	15381-52100	ASSY SHIM INJECTION	1				0.022	0.0484
030	15321-52110	SHIM INJECTION PUMP	1				0	0
040	15531-52110	SHIM INJECTION PUMP	2				0.005	0.011
050	01123-50822	BOLT	2				0.012	0.0264
060	15221-91530	STUD	2				0.011	0.0242
070	02156-50080	NUT	2				0.004	0.0088
080	04512-50080	WASHER SPRING	2				0.001	0.0022
090	15381-16020	ASSY CAMSHAFT FUEL	1				1.1	2.42
100	15381-16170	CAMSHAFT FUEL	1				0.42	0.924
110	08153-06004	BEARING BALL	1				0.07	0.154
120	15261-51150	GEAR INJECTION PUMP	1				0.463	1.0186
130	05712-00520	KEY FEATHER	1				0.004	0.0088
140	15261-55450	SLEEVE GOVERNOR	1				0.058	0.1276
150	15261-55470	CIR-CLIP GOV. SLEEVE	1				0.002	0.0044
160	15261-55690	CASE GOVERNOR BALL	1	<=778923			0	0
160	15549-55690	CASE GOVERNOR BALL	1	>=778924	↔		0.62	1.364
170	07715-03205	BALL	30				0.001	0.0022
180	15261-55740	CIR-CLIP	1				0.002	0.0044
190	07715-03217	BALL	8				0.01	0.022
200	04612-00180	CIR CLIP EXTERNAL	1				0.001	0.0022
210	08103-06004	BEARING BALL	1				0.066	0.1452
220	04612-00200	CIR CLIP EXTERNAL	1				0.001	0.0022
230	15261-16320	STOPPER FUEL.C/SHAFT	1				0.037	0.0814
240	01053-50612	BOLT	2				0.004	0.0088
250	04512-50060	WASHER SPRING	2			0	0	

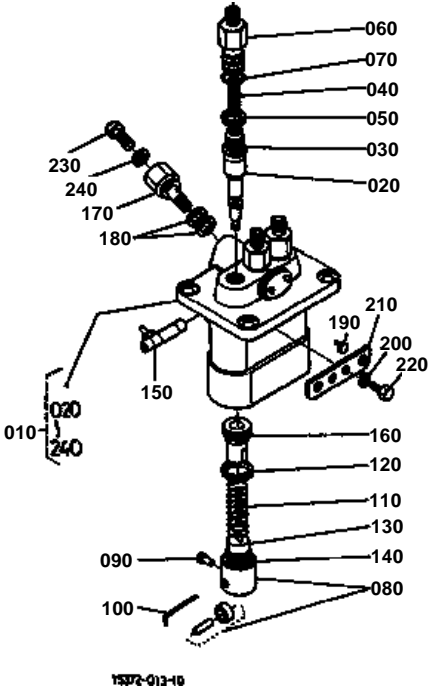



INJECTION PUMP [COMPONENT PARTS] TRACTOR S.No.:B7100HST-D >=60164
B7100HST-E >=20025

↔ Interchangeable; ≠ not interchangeable; ← new for old; → old for new

REF.No	Part No.	Description	Q'ty	S.No.	I/C	REMARKS	Weight (kgf)	Weight (lb)
010	15381-51010	ASSY PUMP INJECTION	1				2.16	4.752
020	15261-51050	PLUNGER PUMP	3				0.04	0.088
030	15261-51030	VALVE DELIVERY	3				0.011	0.0242
040	15331-51230	SPRING DELIV.VALVE	3				0.001	0.0022
050	15331-51240	GASKET DELIV.VALVE	3				0.001	0.0022
060	15331-51220	HOLDER DELIV.VALVE	3				0.053	0.1166
070	15331-96760	O RING	3				0.001	0.0022
080	15331-51070	ASSY TAPPET	3				0.036	0.0792
090	15331-51250	PIN TAPPET GUIDE	3				0.001	0.0022
100	15331-51430	PIN CLAMP	1				0.001	0.0022
110	17331-51280	SPRING PLUNGER	3				0.017	0.0374
120	15331-51270	SEAT SPRING UPPER	3				0.001	0.0022
130	15331-51290	SEAT SPRING LOWER	3				0.001	0.0022
140	15381-51490	SHIM	3				0.008	0.0176
150	15331-51062	RACK CONTROL	1				0.04	0.088
160	15331-51380	SLEEVE CONTROL	3				0.012	0.0264
170	15241-51320	SCREW FOLLOW	1				0.034	0.0748
180	15331-96650	GASKET	2				0.001	0.0022
190	15331-51480	COLLAR	2				0.005	0.011
200	15381-94090	WASHER SPRING	2				0.002	0.0044
210	15381-51390	PLATE ADJUSTING	1				0.008	0.0176
220	15331-91010	BOLT	2				0.034	0.0748
230	14107-51352	SCREW AIR BREEDER	1				0.01	0.022
240	14111-53380	WASHER	1				0.001	0.0022

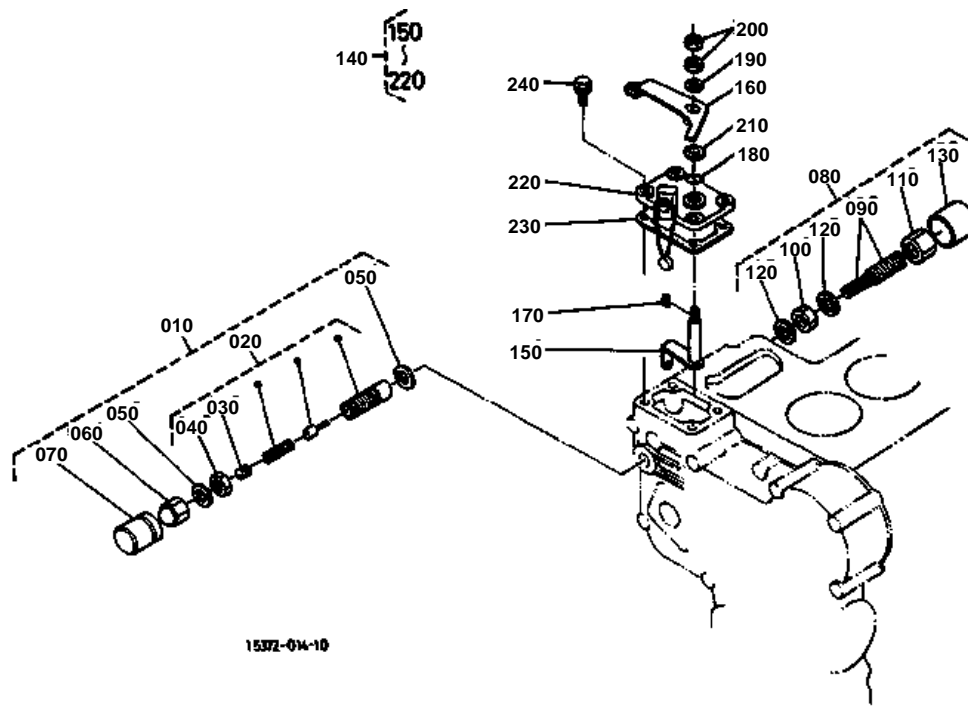



↔ Interchangeable; ≠ not interchangeable; ← new for old; → old for new

REF.No	Part No.	Description	Q'ty	S.No.	I/C	REMARKS	Weight (kgf)	Weight (lb)
010	15371-54020	APPARATUS FUEL LIMIT	1				0.055	0.121
020	15371-54030	APPARATUS FUEL LIMIT	1				0.031	0.0682
030	14301-54430	SCREW SET	1				0.001	0.0022
040	15261-54370	NUT LOCK	1				0.007	0.0154
050	15109-33660	GASKET	2				0.001	0.0022
060	15261-54220	NUT CAP	1				0.02	0.044
070	14301-54420	CAP	1				0.005	0.011
080	15261-54090	ASSY APPARATUS I/D.	1				0.027	0.0594
090	15261-54100	ASSY BOLT ADJUSTING	1				0.008	0.0176
100	15261-92020	NUT	1				0.004	0.0088
110	15261-92330	NUT CAP	1				0.01	0.022
120	15021-33660	GASKET	2				0.001	0.0022
130	15261-54270	CAP	1				0.002	0.0044
140	15971-57000	PLATE SPEED CONTROL	1				0.14	0.308
150	15261-56023	COMP.LEVER GOVERNOR	1				0.02	0.044
160	15371-57152	LEVER SPEED CONTROL	1				0.04	0.088
170	05712-00410	KEY FEATHER	1				0.001	0.0022
180	04811-00070	O RING	1				0.001	0.0022
190	04013-50060	WASHER PLAIN	1				0	0
200	02012-50060	NUT	2				0	0
210	15261-94010	WASHER PLAIN	1				0.002	0.0044
220	15261-57110	PLATE SPEED CONTROL	1				0.06	0.132
230	15261-57210	GASKET	1				0	0
240	01023-50620	BOLT	4				0.006	0.0132

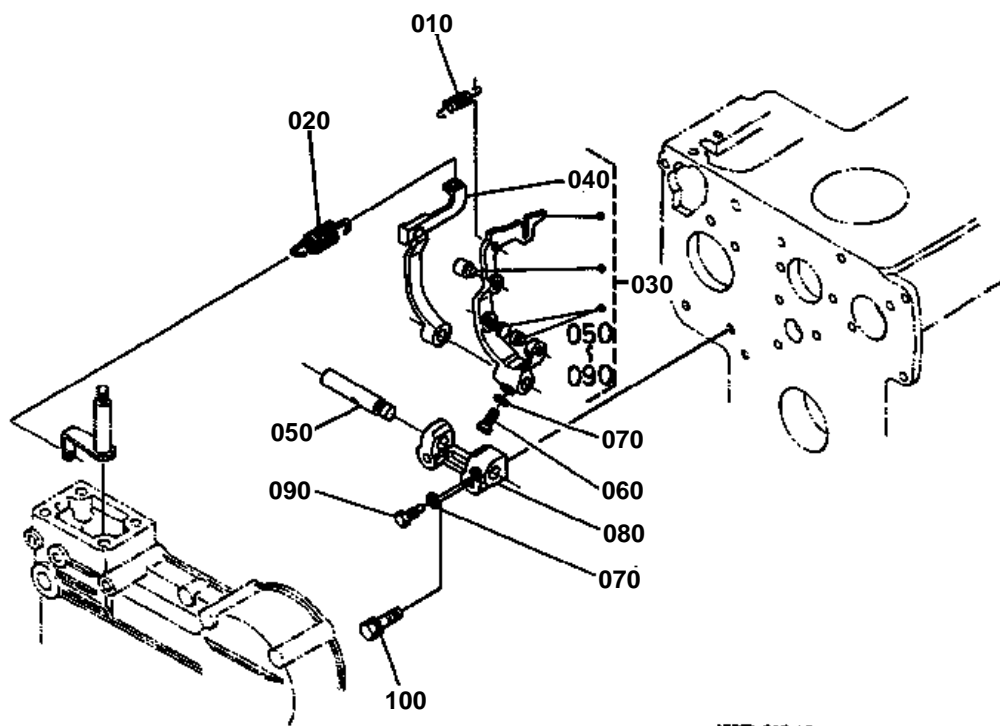



↔ Interchangeable; ≠ not interchangeable; ← new for old; → old for new

REF.No	Part No.	Description	Q'ty	S.No.	I/C	REMARKS	Weight (kgf)	Weight (lb)
010	15221-56480	SPRING START	1				0.008	0.0176
020	15371-56410	SPRING GOVERNOR	1				0.006	0.0132
030	15381-56050	ASSY LEVER FORK	1				0.254	0.5588
040	15261-56130	LEVER FORK	1				0.063	0.1386
050	15261-56150	SHAFT FORK LEVER	1				0.032	0.0704
060	01053-50516	BOLT	1				0.003	0.0066
070	04512-50050	WASHER SPRING	2				0	0
080	15261-56230	HOLDER FORK LEVER	1				0.038	0.0836
090	15261-66410	BOLT	1				0.003	0.0066
100	01023-50628	BOLT	2				0.015	0.033

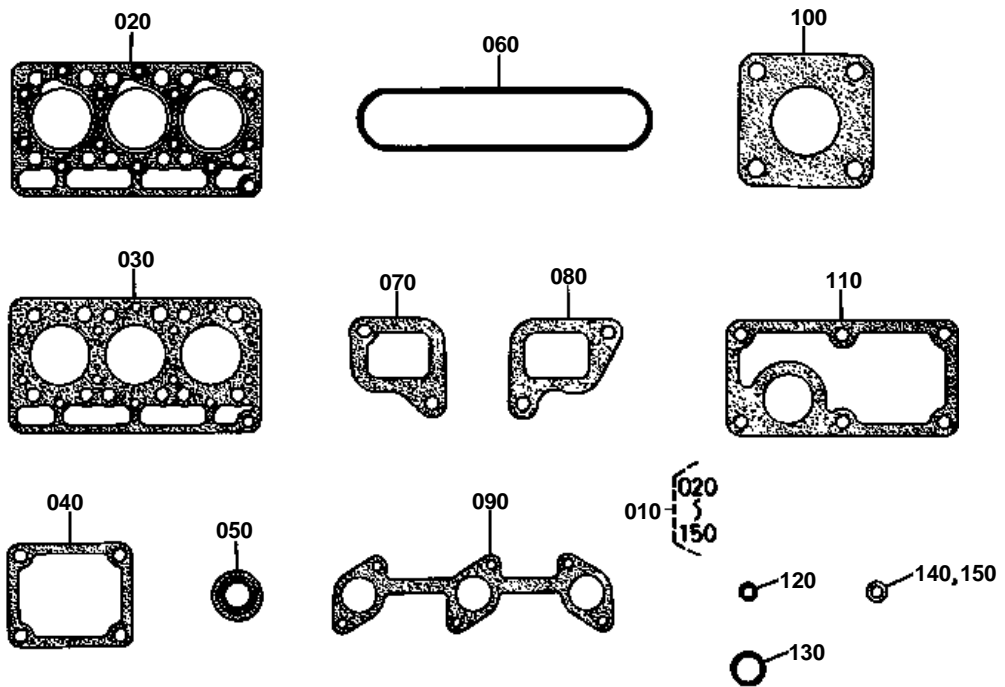

66705-049-10



UPPER GASKET KIT TRACTOR S.No.:B7100HST-D >=60164 B7100HST-E >=20025

↔ Interchangeable; ≠ not interchangeable; ← new for old; → old for new

REF.No	Part No.	Description	Q'ty	S.No.	I/C	REMARKS	Weight (kgf)	Weight (lb)
010	07916-24192	UPPER GASKET KIT	1				0	0
020	15371-03312	GASKET CYLINDER HEAD	1				0	0
030	15371-03322	SHIM CYL.HEAD GASKET	1				0.029	0.0638
040	15231-05130	GASKET BREATHER	1				0	0
050	15261-13150	SEAL VALVE STEM	6				0.001	0.0022
060	15381-14520	GASKET HEAD COVER	1				0.005	0.011
070	15261-11830	GASKET IN-MANIFOLD	2				0	0
080	15261-11820	GASKET IN-MANIFOLD	1				0	0
090	15381-12360	GASKET EX-MANIFOLD	1				0	0
100	15263-12370	GASKET MUFFLER	1				0.015	0.033
110	15261-72920	GASKET WATER FLANGE	1				0	0
120	15221-33700	O RING	1				0.001	0.0022
130	04811-50300	O RING	1				0.001	0.0022
140	17011-53620	GASKET	3				0.003	0.0066
150	15951-96660	GASKET	3				0.001	0.0022

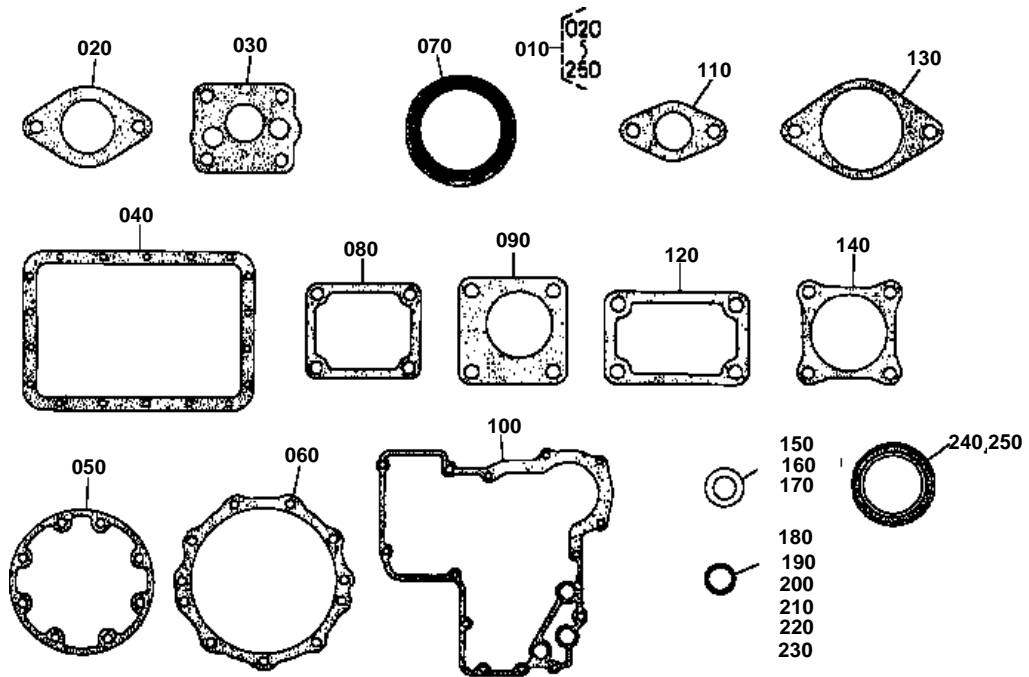

64705-050-10

**LOWER GASKET KIT TRACTOR S.No.:B7100HST-D >=60164 B7100HST-E >=20025**

↔ Interchangeable; ≠ not interchangeable; ← new for old; → old for new

REF.No	Part No.	Description	Q'ty	S.No.	I/C	REMARKS	Weight (kgf)	Weight (lb)
010	07916-29862	LOWER GASKET KIT	1				0	0
020	15261-73920	GASKET WATER COVER	1				0	0
030	15261-35150	GASKET OIL PUMP	1				0	0
040	15381-01620	GASKET OIL PAN	1				0	0
050	15261-04360	GASKET BRG.CASE	1				0	0
060	15261-04820	GASKET BRG.CASE COV.	1				0	0
070	19215-04460	SEAL OIL	1				0.03	0.066
080	15231-05130	GASKET BREATHER	1				0	0
090	15221-88130	GASKET H/METER UNIT	1				0	0
100	15261-04132	GASKET GEAR CASE	1				0	0
110	15241-52140	GASKET FUEL PUMP	1				0	0
120	15261-57210	GASKET	1				0	0
130	66591-51160	GASKET	1				0	0
140	15231-87130	GASKET HYD.PUMP	1				0	0
150	15109-33660	GASKET	1				0.001	0.0022
160	15109-33660	GASKET	2				0.001	0.0022
170	15021-33660	GASKET	2				0.001	0.0022
180	04810-00140	O RING	1				0.001	0.0022
190	04811-10220	O RING	1				0.001	0.0022
200	04811-06130	O RING	3				0.001	0.0022
210	04810-00150	O RING	1				0.001	0.0022
220	04811-00070	O RING	1				0.001	0.0022
230	04811-10070	O RING	1				0.001	0.0022
240	09400-14247	SEAL OIL	1				0.004	0.0088
250	09550-00008	SEAL OIL	1				0.01	0.022

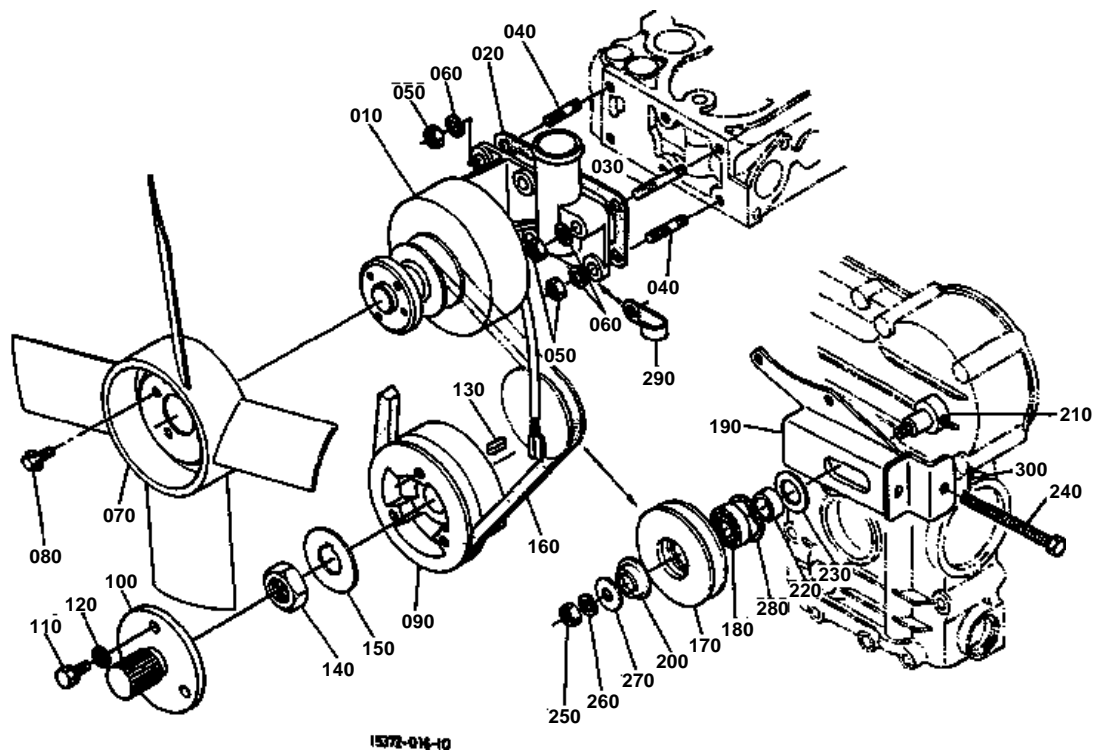



↔ Interchangeable; ≠ not interchangeable; ← new for old; → old for new

REF.No	Part No.	Description	Q'ty	S.No.	I/C	REMARKS	Weight (kgf)	Weight (lb)
010	15372-64010	ASSY DYNAMO	1			REFER TO L.No.0B16-R0 FOR COMPONENTS.	1.7	3.74
020	15261-72920	GASKET WATER FLANGE	1				0	0
030	01513-50645	STUD	1				0.011	0.0242
040	01513-50616	STUD	5				0.004	0.0088
050	02056-50060	NUT	6				0.002	0.0044
060	04512-50060	WASHER SPRING	6				0	0
070	15553-74110	FAN	1				0.3	0.66
080	01754-50610	BOLT FLANGE	4				0.006	0.0132
090	15372-74280	PULLEY FAN DRIVE	1				0.9	1.98
100	66704-88530	FLANGE PTO	1				0.4	0.88
110	01123-50825	BOLT	3				0.013	0.0286
120	04013-50080	WASHER PLAIN	3				0	0
130	05712-00515	KEY FEATHER	1				0.003	0.0066
140	15261-23360	NUT CRANKSHAFT	1				0.034	0.0748
150	15372-23380	WASHER CRANKSHAFT	1				0.007	0.0154
160	15231-72530	BELT FAN	1				0.066	0.1452
170	14301-74320	PULLEY TENSION	1				0	0
180	15271-74190	BEARING	1				0.065	0.143
190	15371-74410	SUPPORT TEN.PULLEY	1				0.33	0.726
200	15231-74770	COVER TENSION PULLEY	1				0.004	0.0088
210	15231-74330	SHAFT TENSION PULLEY	1				0.093	0.2046
220	15261-74430	COLLAR	1				0.013	0.0286
230	14301-74780	COVER TENSION PULLEY	1				0.005	0.011
240	15371-74970	BOLT TENSION	1				0.032	0.0704
250	02018-50100	NUT	1				0.011	0.0242
260	04512-50100	WASHER SPRING	1				0	0
270	04013-50100	WASHER PLAIN	1				0	0
280	04611-00400	CIR CLIP INTERNAL	1				0.005	0.011
290	15272-67590	CLAMP CORD	1				0.004	0.0088
300	99999-99999	WIRE	1				OBTAINED LOCALLY	0

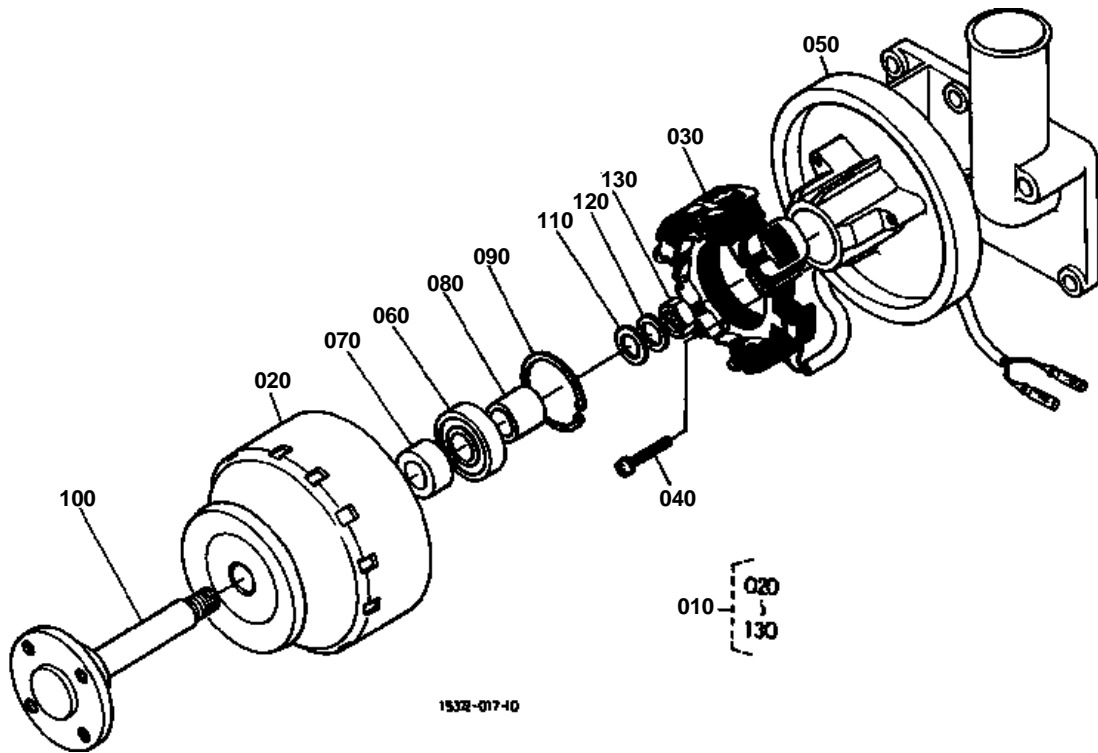



↔ Interchangeable; ≠ not interchangeable; ← new for old; → old for new

REF.No	Part No.	Description	Q'ty	S.No.	I/C	REMARKS	Weight (kgf)	Weight (lb)
010	15372-64010	ASSY DYNAMO	1				1.7	3.74
020	15372-64040	ROTOR	1				0.95	2.09
030	15372-64290	ASSY STATOR	1				0.23	0.506
040	15261-93010	SCREW ROUND HEAD	2				0.003	0.0066
050	15372-64362	BASE STATOR	1				0.4	0.88
060	15531-74180	BEARING BALL	1				0.04	0.088
070	15261-64140	COLLAR	1				0.025	0.055
080	15261-64150	COLLAR	1				0.02	0.044
090	15261-95470	CIR CLIP INTERNAL	1				0.002	0.0044
100	15372-74140	SHAFT FAN	1				0.22	0.484
110	15261-94020	WASHER PLAIN	1				0.007	0.0154
120	15261-94070	WASHER SPRING	1				0.003	0.0066
130	15261-92030	NUT	1				0.01	0.022

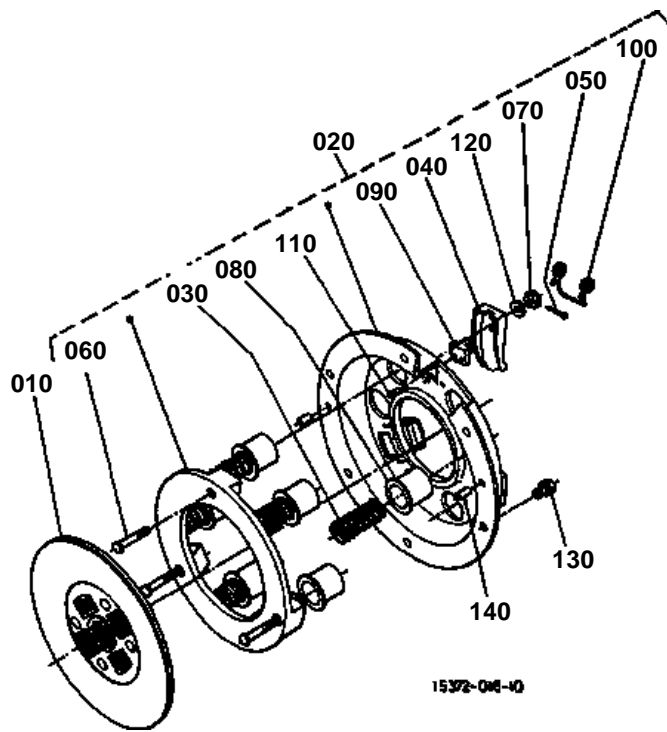



↔ Interchangeable; ≠ not interchangeable; ← new for old; → old for new

REF.No	Part No.	Description	Q'ty	S.No.	I/C	REMARKS	Weight (kgf)	Weight (lb)
010	66905-13300	ASSY DISK CLUTCH	1				0.93	2.046
020	66591-13400	ASSY PLATE PRESSURE	1				3.1	6.82
030	66591-13310	SPRING PRESSURE	6				0.058	0.1276
040	32200-14540	LEVER CLUCH	3				0.05	0.11
050	32130-14560	PIN SPLIT	3				0.001	0.0022
060	32200-14570	BOLT	3				0.009	0.0198
070	32130-14580	NUT	3				0.003	0.0066
080	32130-14590	CAP PRESSURE SPRING	6				0.024	0.0528
090	32130-14620	SEAT LEVER	3				0.017	0.0374
100	32130-14630	SPRING RETURN	3				0.006	0.0132
110	32130-14640	RIVET	6				0.001	0.0022
120	32130-14650	WASHER RELEASE YOKE	3				0.002	0.0044
130	01123-50816	BOLT	6				0.011	0.0242
140	05012-00614	PIN STRAIGHT	2				0.004	0.0088

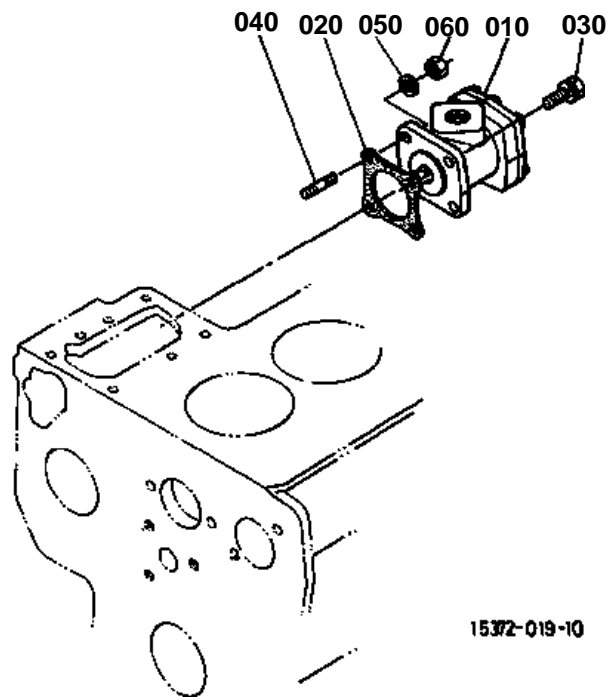

15372-019-10



↔ Interchangeable; ≠ not interchangeable; ← new for old; → old for new

REF.No	Part No.	Description	Q'ty	S.No.	I/C	REMARKS	Weight (kgf)	Weight (lb)
010	67211-76100	ASSY PUMP GEAR	1			REFER TO L.No.0D12-R0 FOR COMPONENTS.	1.45	3.19
020	15231-87130	GASKET HYD.PUMP	1				0	0
030	01153-50822	BOLT	3				0.011	0.0242
040	01513-50822	STUD	1				0.01	0.022
050	04512-50080	WASHER SPRING	4				0.001	0.0022
060	02156-50080	NUT	1				0.004	0.0088

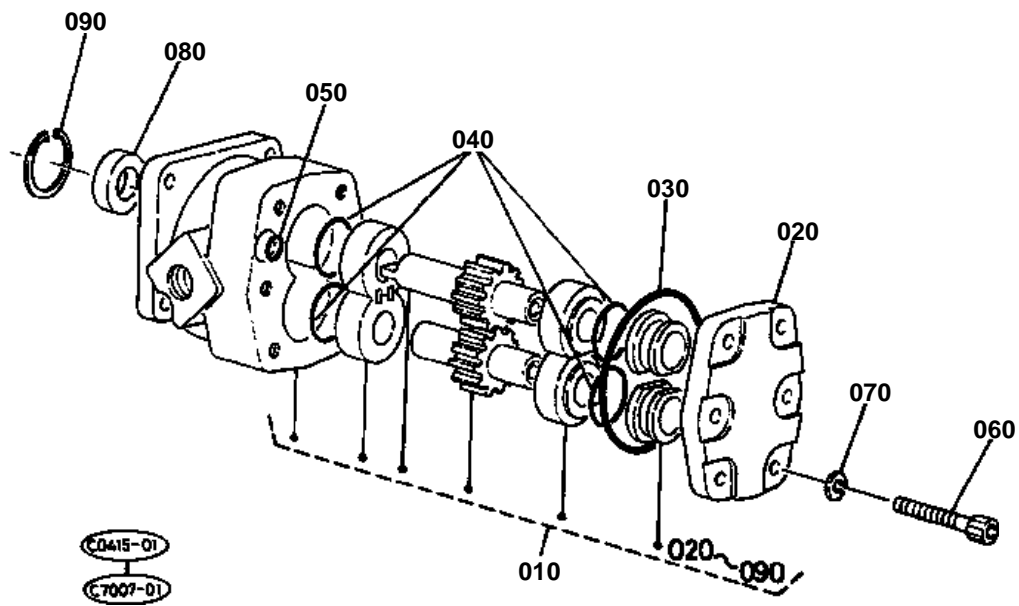



↔ Interchangeable; ≠ not interchangeable; ← new for old; → old for new

REF.No	Part No.	Description	Q'ty	S.No.	I/C	REMARKS	Weight (kgf)	Weight (lb)
010	67211-76100	ASSY PUMP GEAR	1				1.45	3.19
020	67211-76120	COVER	1				0.18	0.396
030	04810-50500	O RING	1				0.005	0.011
040	04810-00220	O RING	4				0.001	0.0022
050	04810-00050	O RING	1				0.001	0.0022
060	67211-76240	BOLT	6				0.014	0.0308
070	04512-50080	WASHER SPRING	6				0.001	0.0022
080	31381-76190	SEAL OIL	1				0.007	0.0154
090	04611-00280	CIR CLIP INTERNAL	1				0.002	0.0044

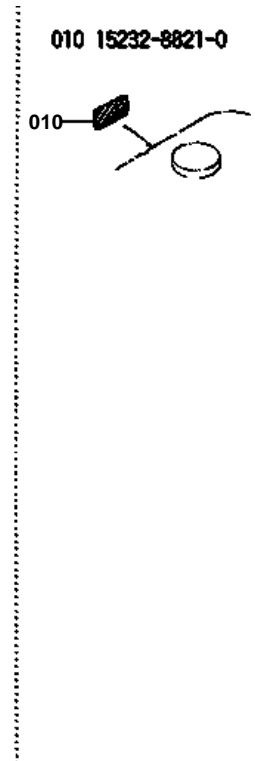
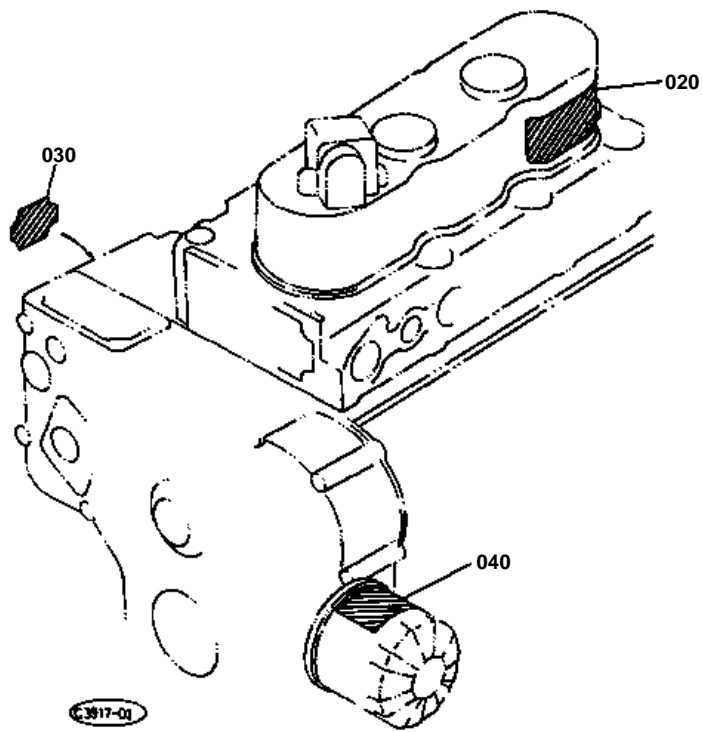



LABEL 1 TRACTOR S.No.:B7100HST-D >=60164 B7100HST-E >=20025

↔ Interchangeable; ≠ not interchangeable; ← new for old; → old for new

REF.No	Part No.	Description	Q'ty	S.No.	I/C	REMARKS	Weight (kgf)	Weight (lb)
010	15232-88210	LABEL GLOW PLUG	1	<=795143			0.001	0.0022
020	15372-87310	LABEL OIL	1				0.001	0.0022
030	15372-87230	LABEL CAUTION	1				0.001	0.0022
040	15372-87210	LABEL CAUTION	1				0.001	0.0022

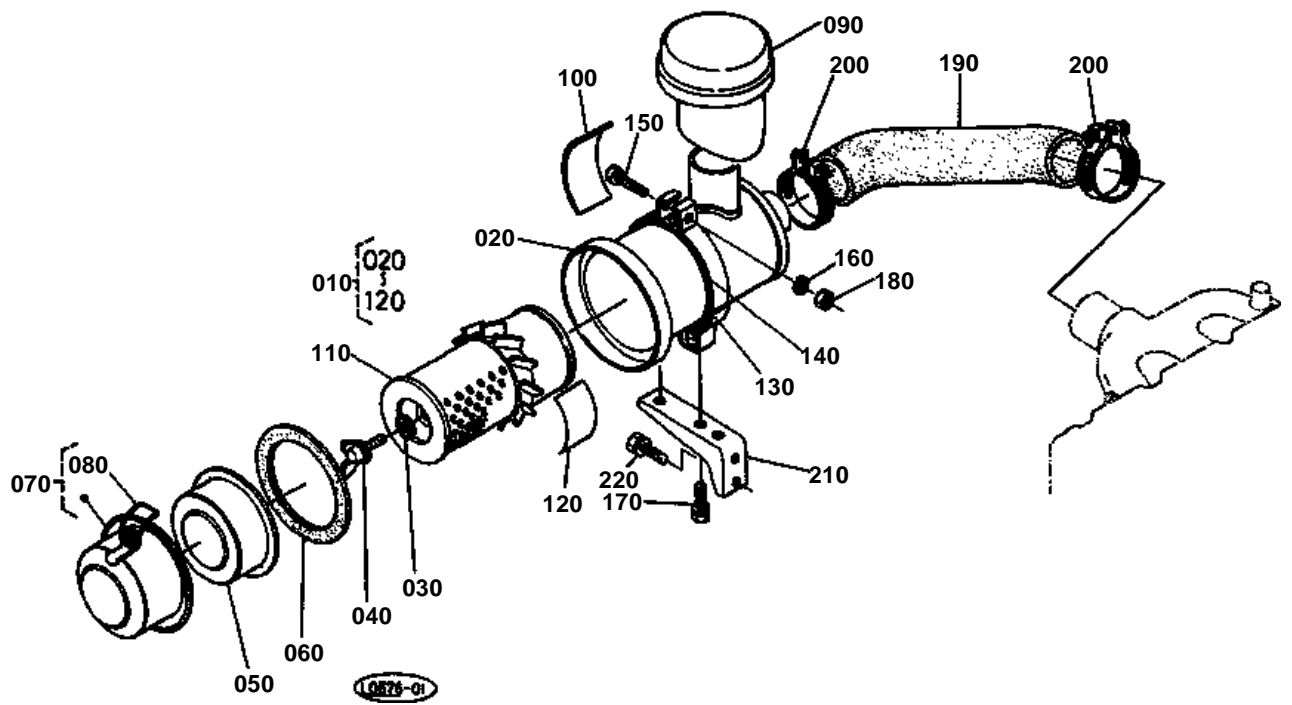



↔ Interchangeable; ≠ not interchangeable; ← new for old; → old for new

REF.No	Part No.	Description	Q'ty	S.No.	I/C	REMARKS	Weight (kgf)	Weight (lb)
010	15372-11010	ASSY CLEANER AIR	1				0	0
020	15241-11150	BODY AIR CLEANER	1				0.69	1.518
030	15221-94430	WASHER WITH RUBBER	1				0.004	0.0088
040	15221-92620	BOLT WING	1				0.04	0.088
050	15221-11410	COVER BAFFLE	1				0.104	0.2288
060	15221-11170	GASKET A/C COVER	1				0.01	0.022
070	15241-11160	COVER AIR CLEANER	1				0.255	0.561
080	66704-85820	HOOK A/C COVER	1				0.009	0.0198
090	15241-11350	CAP AIR CLEANER	1				0.48	1.056
100	15372-87452	LABEL AIR CLEANER	1				0.001	0.0022
110	15222-11220	ELEMENT AIR CLEANER	1				0.344	0.7568
120	15227-87480	LABEL ELEMENT A/C	1				0.004	0.0088
130	15381-11250	BAND AIR CLEANER	1	<=63115			0.21	0.462
130	15371-11252	BAND AIR CLEANER	1	>=63116	←		0.21	0.462
140	15371-11870	CUSHION	1				0.025	0.055
150	01222-50830	BOLT	1				0.013	0.0286
160	04512-50080	WASHER SPRING	1				0.001	0.0022
170	01123-50816	BOLT	2				0.011	0.0242
180	02114-50080	NUT	1				0.005	0.011
190	15371-11620	PIPE INLET	1				0.2	0.44
200	15221-11720	BAND PIPE	2				0.03	0.066
210	66711-54310	STAY AIR CLEANER	1				0.306	0.6732
220	01123-50820	BOLT	2				0.011	0.0242

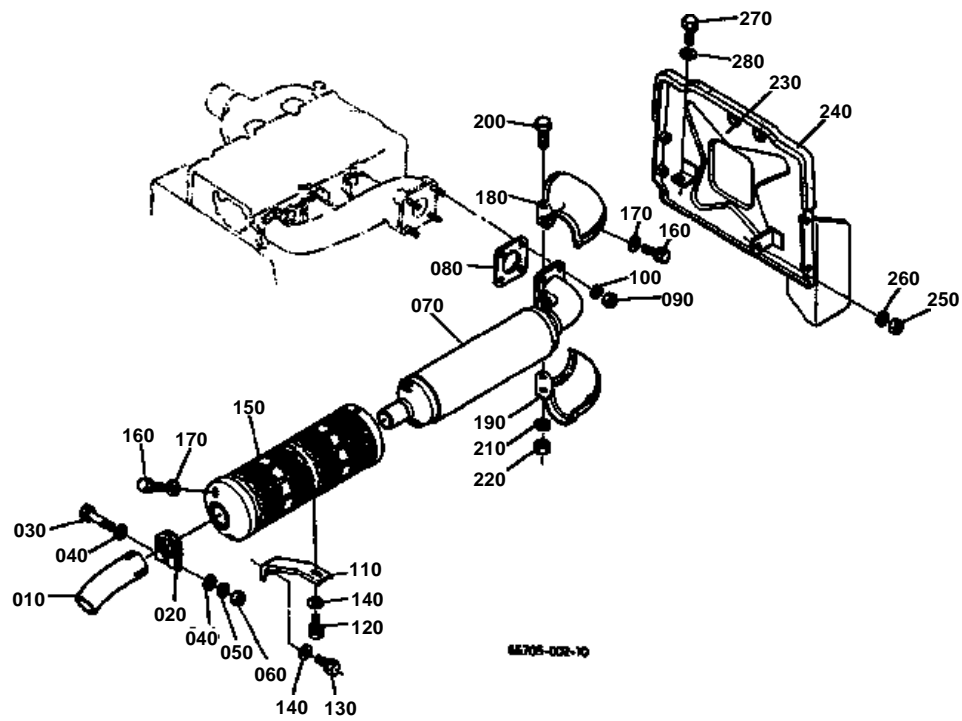



↔ Interchangeable; ≠ not interchangeable; ← new for old; → old for new

REF.No	Part No.	Description	Q'ty	S.No.	I/C	REMARKS	Weight (kgf)	Weight (lb)
010	66711-54410	PIPE EXHAUST	1				0.137	0.3014
020	66711-54420	BAND PIPE	1				0.038	0.0836
030	01153-50865	BOLT	1				0.025	0.055
040	04013-50080	WASHER PLAIN	2				0	0
050	04512-50080	WASHER SPRING	1				0.001	0.0022
060	02114-50080	NUT	1				0.005	0.011
070	66706-54510	MUFFLER	1				2.8	6.16
080	15263-12370	GASKET MUFFLER	1				0.015	0.033
090	02114-50080	NUT	4				0.005	0.011
100	04512-50080	WASHER SPRING	4				0.001	0.0022
110	66732-54530	STAY MUFFLER	1				0.1	0.22
120	01123-50814	BOLT	1				0	0
130	01123-50818	BOLT	1				0.012	0.0264
140	04013-50080	WASHER PLAIN	2				0	0
150	66711-54520	COVER MUFFLER	1				0.878	1.9316
160	01202-50612	BOLT	4				0.005	0.011
170	04013-50060	WASHER PLAIN	4				0	0
180	66711-54550	COVER MUFFLER FLANGE	1				0.137	0.3014
190	66711-54560	COVER MUFFLER FLANGE	1				0.135	0.297
200	01053-50628	BOLT	2				0.008	0.0176
210	04512-50060	WASHER SPRING	2				0	0
220	02014-50060	NUT	2				0.003	0.0066
230	66711-54610	PLATE SHUTTER	1				1.066	2.3452
240	66711-54620	TAPE SOFT	1				0.005	0.011
250	02114-50080	NUT	1				0.005	0.011
260	04512-50080	WASHER SPRING	1				0.001	0.0022
270	01123-50818	BOLT	1				0.012	0.0264
280	04013-50080	WASHER PLAIN	1				0	0

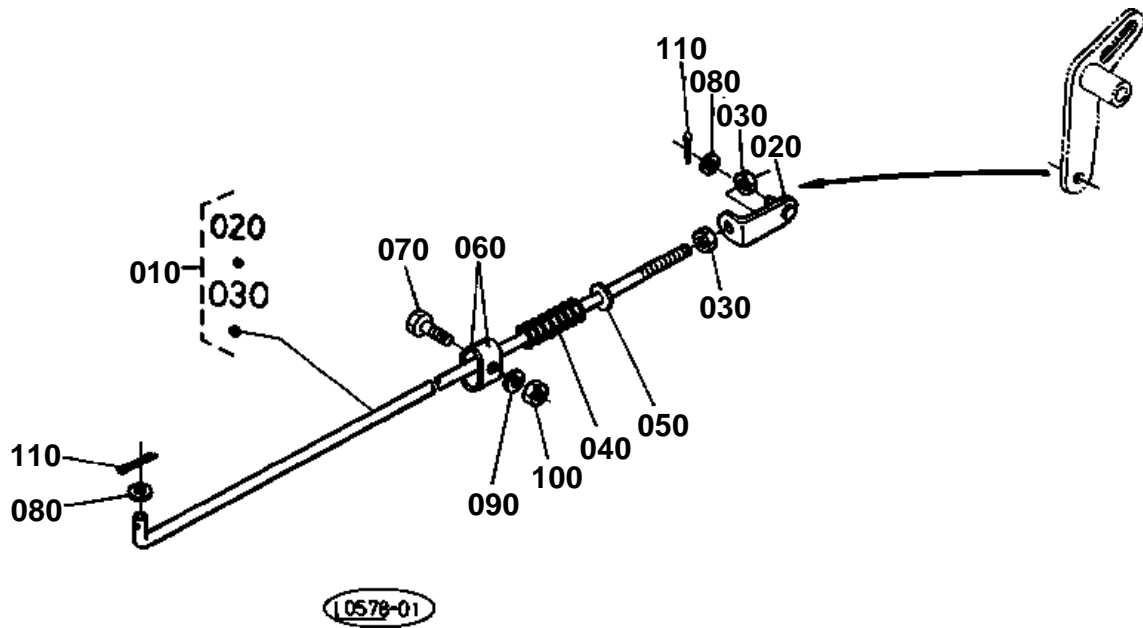



↔ Interchangeable; ≠ not interchangeable; ← new for old; → old for new

REF.No	Part No.	Description	Q'ty	S.No.	I/C	REMARKS	Weight (kgf)	Weight (lb)
010	66204-43200	ASSY ROD RELEASE	1				0.15	0.33
020	66711-43220	MATERIAL L	1				0.023	0.0506
030	02014-50060	NUT	2				0.003	0.0066
040	66204-43272	SPRING	1				0.014	0.0308
050	04015-50060	WASHER PLAIN	1				0	0
060	66204-54650	STOPPER	2				0.007	0.0154
070	01053-50620	BOLT	1				0.006	0.0132
080	04013-50060	WASHER PLAIN	2				0	0
090	04512-50060	WASHER SPRING	1				0	0
100	02014-50060	NUT	1				0.003	0.0066
110	05511-51612	PIN SPLIT	2				0.001	0.0022

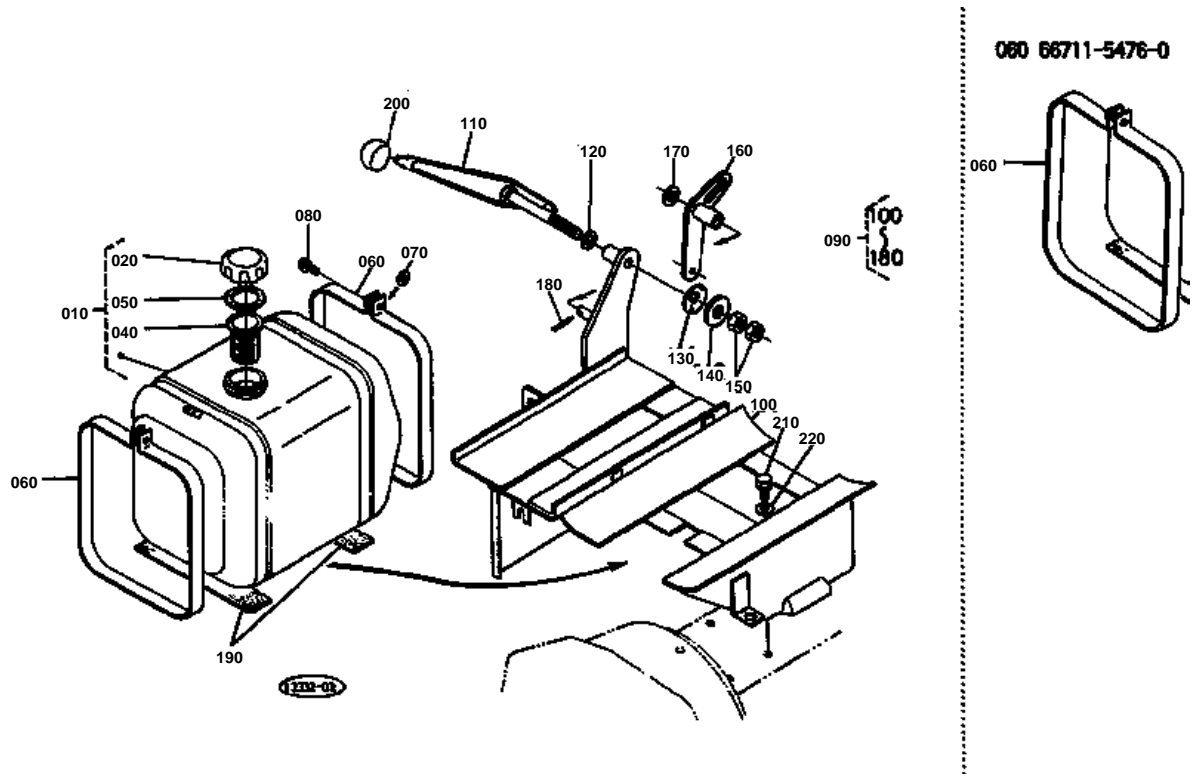



↔ Interchangeable; ≠ not interchangeable; ← new for old; → old for new

REF.No	Part No.	Description	Q'ty	S.No.	I/C	REMARKS	Weight (kgf)	Weight (lb)
010	66711-54702	ASSY TANK FUEL	1				0	0
020	66711-54820	ASSY CAP FUEL TANK	1				0.03	0.066
030	99999-99999	BLANK	0				0	0
040	13251-41060	FILTER FUEL	1				0.01	0.022
050	10211-41340	GASKET	1				0.003	0.0066
060	66711-54760	BAND FUEL TANK	2	<=67374			0	0
060	66711-54764	BAND FUEL TANK	2	>=67375	←		0.27	0.594
070	04013-50080	WASHER PLAIN	2				0	0
080	01123-50830	BOLT	2				0.015	0.033
090	66204-54805	ASSY SUPPORT TANK BA	1				3.45	7.59
100	66204-54770	SUPPORT TANK BATTERY	1				3.3	7.26
110	66204-43220	LEVER RELEASE	1				0.185	0.407
120	04013-50100	WASHER PLAIN	1				0	0
130	32210-17190	SPRING	1				0.005	0.011
140	04015-50100	WASHER PLAIN	1				0.016	0.0352
150	02116-50100	NUT	2				0.004	0.0088
160	66204-43230	ARM RELEASE	1				0.1	0.22
170	04013-50100	WASHER PLAIN	1				0	0
180	05511-52518	PIN SPLIT	1				0.001	0.0022
190	66641-54740	CUSHION TANK	2				0.065	0.143
200	66611-43240	GRIP LEVER	1				0.018	0.0396
210	01123-50816	BOLT	4				0.011	0.0242
220	04013-50080	WASHER PLAIN	4				0	0

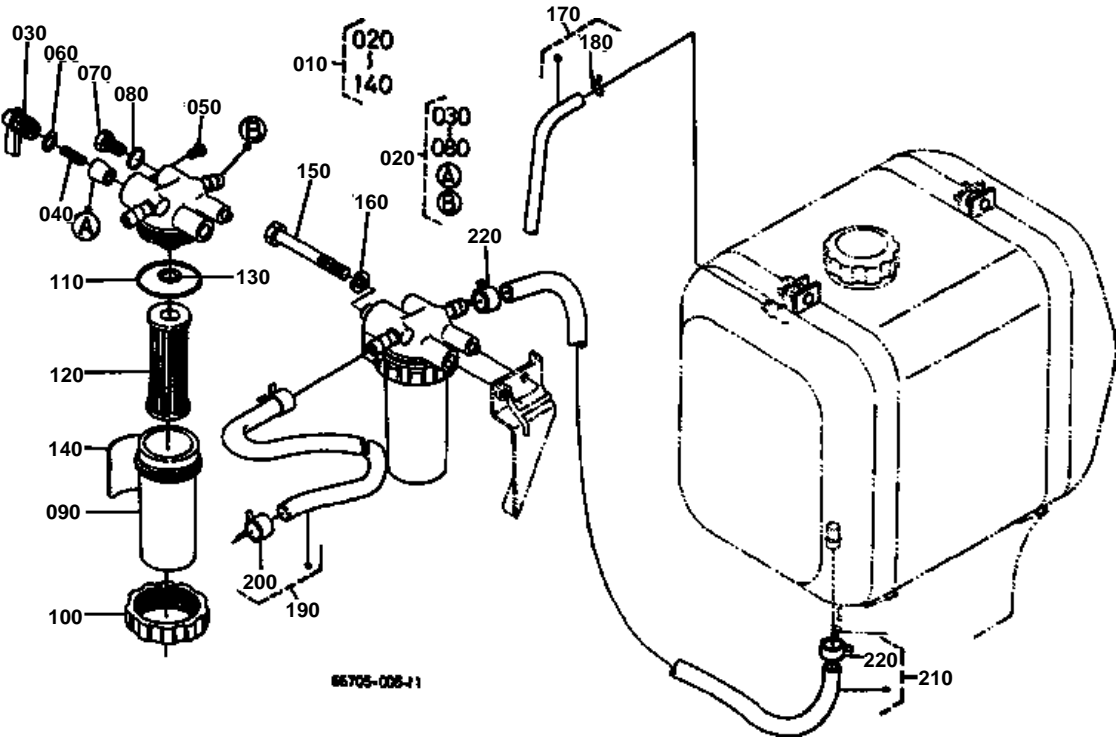



↔ Interchangeable; ≠ not interchangeable; ← new for old; → old for new

REF.No	Part No.	Description	Q'ty	S.No.	I/C	REMARKS	Weight (kgf)	Weight (lb)
010	15372-43010	ASSY FILTER FUEL	1				0	0
020	15261-43110	COMP.BODY COCK	1				0.3	0.66
030	14301-43522	LEVER COCK	1				0.024	0.0528
040	14301-43820	SPRING VALVE	1				0.001	0.0022
050	14301-43830	SCREW	1				0.001	0.0022
060	14301-43840	O RING LEVER	1				0.001	0.0022
070	15231-43283	SCREW AIR BREATHER	2				0.003	0.0066
080	04810-00060	O RING	2				0.001	0.0022
090	15000-34832	CUP FILTER	1				0.07	0.154
100	14301-43590	RING RETAINING	1				0.054	0.1188
110	14301-43650	O RING FILTER	1				0.001	0.0022
120	15231-43560	ASSY ELEMENT	1				0.03	0.066
130	04811-00100	O RING FILTER	1				0.001	0.0022
140	66706-58310	LABEL FUEL FILTER	1				0.001	0.0022
150	01153-50865	BOLT	1				0.025	0.055
160	04512-50080	WASHER SPRING	1				0.001	0.0022
170	15371-42050	ASSY PIPE OVER FLOW	1				0.016	0.0352
180	10244-42320	CLIP PIPE	2				0.001	0.0022
190	66704-58300	ASSY PIPE FUEL	1				0.025	0.055
200	14911-42750	CLIP PIPE	2				0.002	0.0044
210	67136-35610	ASSY TUBE FUEL	1				0.05	0.11
220	14911-42750	CLIP PIPE	2				0.002	0.0044

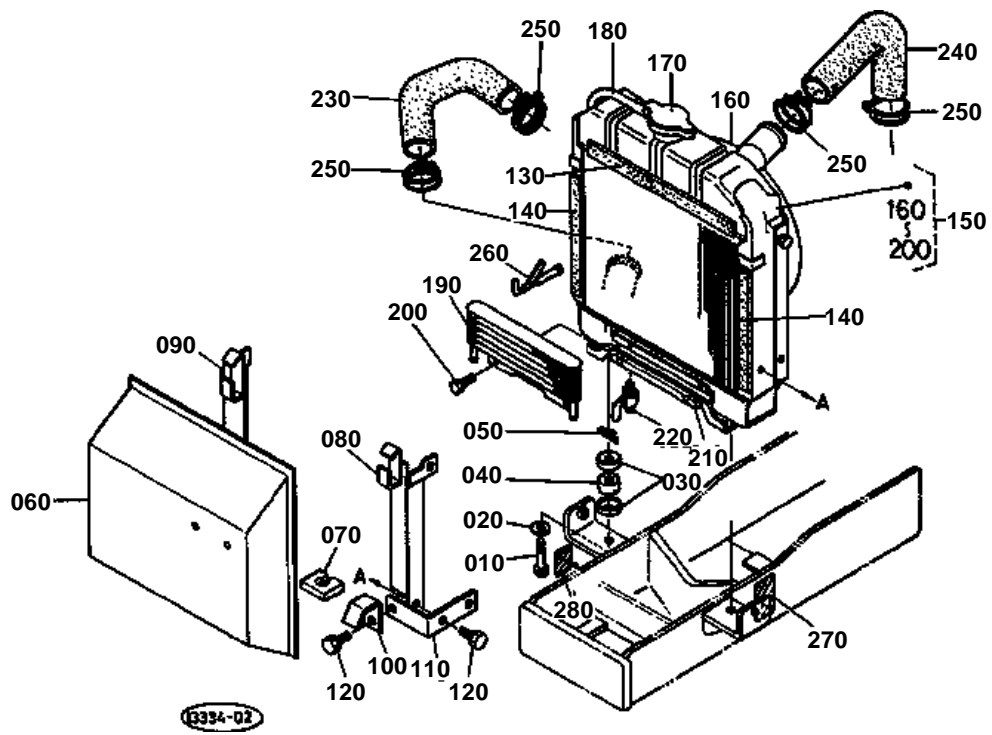



↔ Interchangeable; ≠ not interchangeable; ← new for old; → old for new

REF.No	Part No.	Description	Q'ty	S.No.	I/C	REMARKS	Weight (kgf)	Weight (lb)
010	66711-51340	BOLT RADIATOR	2				0.032	0.0704
020	04013-50100	WASHER PLAIN	2				0	0
030	15111-72200	WASHER	4				0.013	0.0286
040	15111-72180	CUSHION	2				0.015	0.033
050	05515-51000	PIN SNAP	2				0	0
060	66204-51450	NET DUSTPROOF	1				0.96	2.112
070	66204-85220	TAPE NET	2				0.002	0.0044
080	66204-51460	STAY LH	1				0.1	0.22
090	66204-51470	STAY RH	1				0.1	0.22
100	66204-51480	SPRING	2				0.004	0.0088
110	66204-51490	PLATE SPRING	2				0.04	0.088
120	01202-50612	BOLT	8				0.005	0.011
130	66204-51510	TAPE	1				0.009	0.0198
140	66204-51520	TAPE	2				0.004	0.0088
150	15553-72060	ASSY RADIATOR	1				6	13.2
160	15371-74470	COVER FAN	1				0.4	0.88
170	15101-72030	CAP RADIATOR	1				0.075	0.165
180	15401-72710	PIPE WATER OVER FLOW	1				0.032	0.0704
190	66204-58710	COOLER OIL	1				0.38	0.836
200	01202-50612	BOLT	2				0.005	0.011
210	66204-58730	TAPE RADIATOR	1				0.01	0.022
220	14301-73110	COCK DRAIN	1				0.094	0.2068
230	15371-72850	PIPE WATER	1				0.21	0.462
240	15371-72940	PIPE WATER	1				0.164	0.3608
250	15108-72870	BAND	4				0.027	0.0594
260	66204-58750	WHISTLE STEAM	1				0.028	0.0616
270	66706-58810	LABEL RADIATOR	1				0.001	0.0022
280	66706-58820	LABEL	1				0.001	0.0022

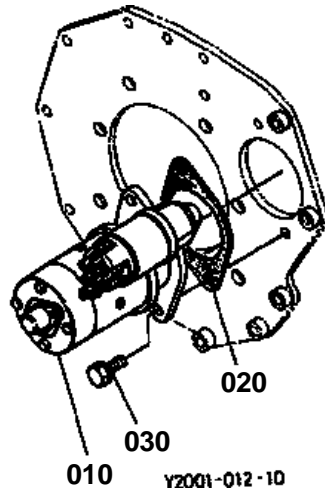



↔ Interchangeable; ≠ not interchangeable; ← new for old; → old for new

REF.No	Part No.	Description	Q'ty	S.No.	I/C	REMARKS	Weight (kgf)	Weight (lb)
010	15231-63015	ASSY STARTER	1			REFER TO L.No.0C01-R0 FOR COMPONENTS.	4.7	10.34
020	66591-51160	GASKET	1				0	0
030	01123-50828	BOLT	2				0.014	0.0308

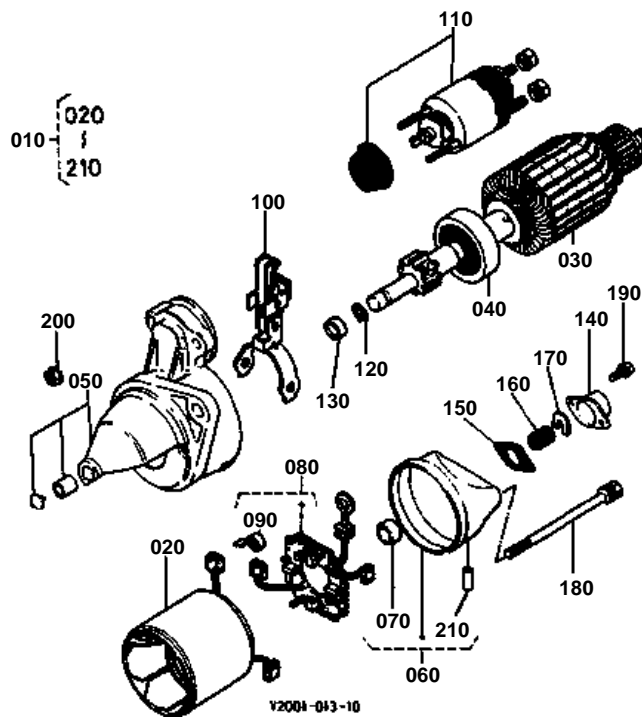



↔ Interchangeable; ≠ not interchangeable; ← new for old; → old for new

REF.No	Part No.	Description	Q'ty	S.No.	I/C	REMARKS	Weight (kgf)	Weight (lb)
010	15231-63015	ASSY STARTER	1				4.7	10.34
020	14278-63080	YOKE	1				1.42	3.124
030	14278-63070	ARMATURE	1				1.25	2.75
040	14278-63040	CLUTCH OVER RUNNING	1				0.32	0.704
050	15231-63032	ASSY HOUSING	1				0.39	0.858
060	14278-63200	ASSY FRAME END	1				0.2	0.44
070	14278-63250	BUSH	1				0.002	0.0044
080	14278-63380	ASSY HOLDER BRUSH	1				0.06	0.132
090	14278-63390	SPRING BRUSH	4				0.003	0.0066
100	14278-63050	LEVER DRIVE	1				0.06	0.132
110	15231-63022	SWITCH MAGNETIC	1				0.65	1.43
120	15221-94820	PIN SNAP	1				0.001	0.0022
130	15321-63250	NUT PINION STOP	1				0.005	0.011
140	14278-63510	CAP END FRAME	1				0.015	0.033
150	14278-63520	GASKET	1				0.001	0.0022
160	14278-63190	SPRING BRAKE	1				0.01	0.022
170	14278-63180	SHOE BRAKE	1				0.005	0.011
180	14278-63320	BOLT THROUGH	2				0.02	0.044
190	03024-50414	SCREW WITH WASHER	2				0.002	0.0044
200	14278-92010	NUT	2				0.001	0.0022
210	14278-63570	PIPE BREATHER	1				0.001	0.0022

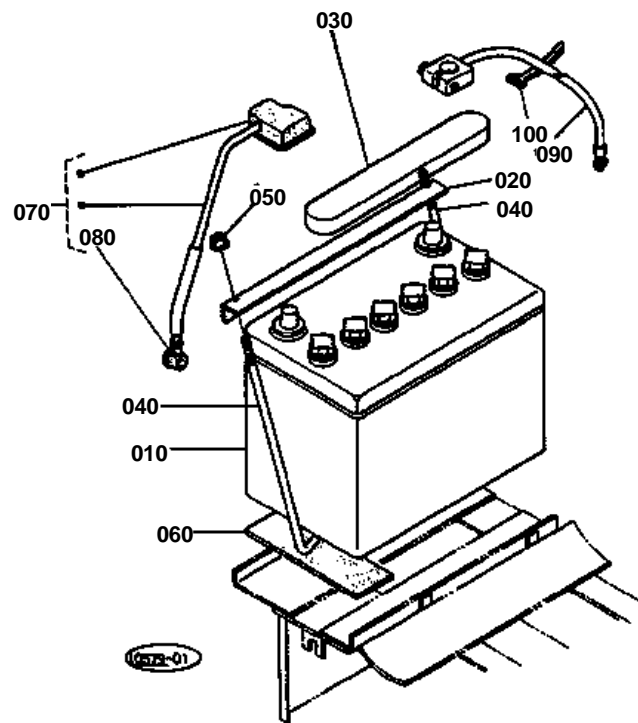



↔ Interchangeable; ≠ not interchangeable; ← new for old; → old for new

REF.No	Part No.	Description	Q'ty	S.No.	I/C	REMARKS	Weight (kgf)	Weight (lb)
010	66704-55430	ASSY BATTERY	1	<=65015			9.3	20.46
010	66704-55433	ASSY BATTERY	1	>=65016	≠		9.3	20.46
020	67061-54484	RETAINER BATTERY	1				0.2	0.44
030	66641-55430	COVER BATTERY	1				0.07	0.154
040	66591-54490	BOLT BATTERY SET	2				0.048	0.1056
050	02751-50060	NUT FLANGE	2				0.005	0.011
060	34150-33220	CUSHION	2				0.015	0.033
070	66709-55450	ASSY CORD BATTERY (+	1				0.25	0.55
080	67211-55470	CAP TERMINAL	1				0.002	0.0044
090	66704-55460	CORD BATTERY (-)	1				0.165	0.363
100	66711-55470	CLAMP CORD	1				0.001	0.0022

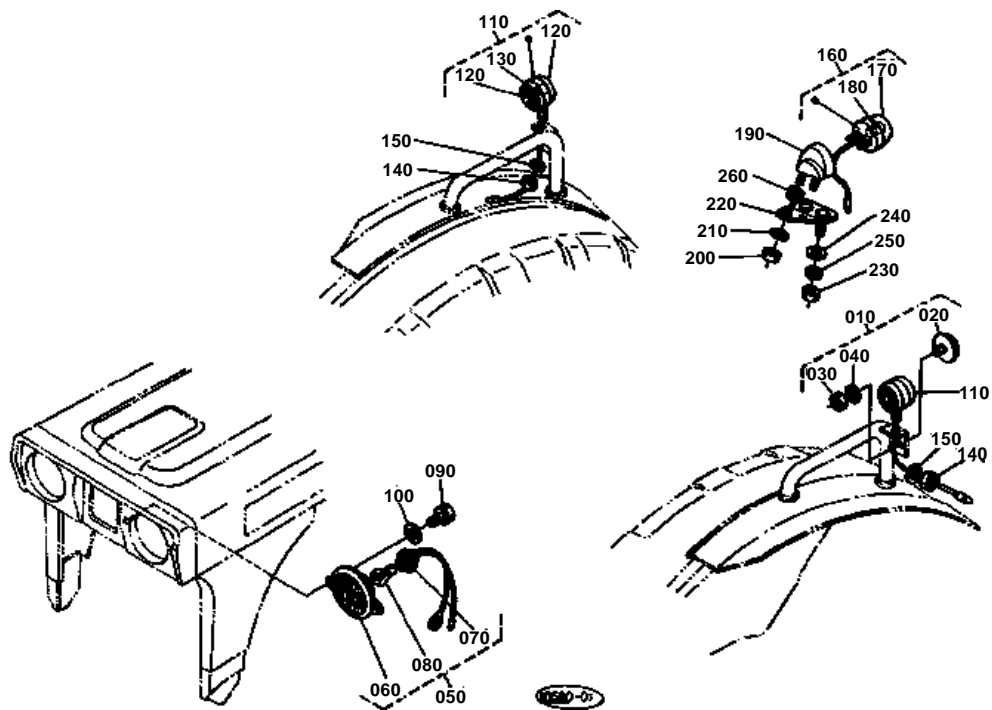



↔ Interchangeable; ≠ not interchangeable; ← new for old; → old for new

REF.No	Part No.	Description	Q'ty	S.No.	I/C	REMARKS	Weight (kgf)	Weight (lb)
010	66591-52300	ASSY REFLECTOR	2				0.006	0.0132
020	53143-61240	COMP REFLECTOR	2				0.009	0.0198
030	02054-50050	NUT	2				0.002	0.0044
040	04512-50050	WASHER SPRING	2				0	0
050	66711-54120	ASSY LIGHT HEAD	2				0.15	0.33
060	66591-55610	LAMP HEAD	2				0.15	0.33
070	66711-54130	SOCKET	2				0.016	0.0352
080	66591-55630	BULB LAMP	2				0.008	0.0176
090	01202-50612	BOLT	4				0.005	0.011
100	04013-50060	WASHER PLAIN	4				0	0
110	67111-55470	ASSY LAMP FLASHER	2				0	0
120	67111-55440	LENS	4				0.015	0.033
130	67111-55490	BULB	2				0.018	0.0396
140	02114-50080	NUT	2				0.005	0.011
150	04512-50080	WASHER SPRING	2				0.001	0.0022
160	66704-55520	ASSY LIGHT TAIL	1				0.11	0.242
170	66704-55550	LENS TAIL LIGHT	1				0.045	0.099
180	66704-55560	BULB TAIL LIGHT	1				0.007	0.0154
190	32400-34190	HOLDER TAIL LIGHT	1				0.11	0.242
200	02014-50060	NUT	2				0.003	0.0066
210	04512-50060	WASHER SPRING	2				0	0
220	66722-55530	STAY TAIL LAMP	1				0	0
230	02014-50060	NUT	2				0.003	0.0066
240	04015-50060	WASHER PLAIN	2				0	0
250	04512-50060	WASHER SPRING	2				0	0
260	66591-54580	RUBBER RELEASE ROD	1				0.003	0.0066

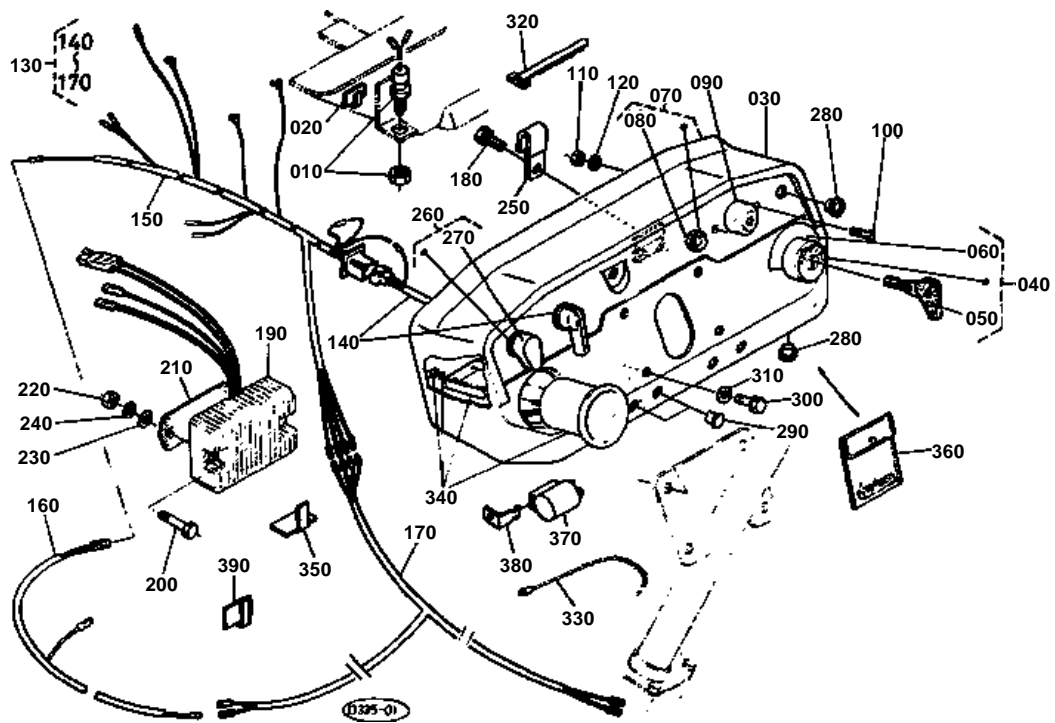



↔ Interchangeable; ≠ not interchangeable; ← new for old; → old for new

REF.No	Part No.	Description	Q'ty	S.No.	I/C	REMARKS	Weight (kgf)	Weight (lb)
010	66416-55810	ASSY SWITCH SAFETY	1				0.11	0.242
020	66611-55190	SUPPORT CORD	1				0.001	0.0022
030	66213-55110	PANEL	1				1.2	2.64
040	66706-55120	ASSY SWITCH STARTER	1				0.256	0.5632
050	66711-55240	KEY START	1				0.02	0.044
060	66706-55150	LABEL STARTER SWITCH	1				0.001	0.0022
070	66711-55290	ASSY LAMP OIL	1				0.016	0.0352
080	34150-34590	BULB	2				0.001	0.0022
090	15231-65950	INDICATOR GLOW PLUG	1				0.045	0.099
100	01053-50512	BOLT	2				0.002	0.0044
110	02054-50050	NUT	2				0.002	0.0044
120	04512-50050	WASHER SPRING	2				0	0
130	66204-55162	ASSY WIRE HARNESS	1				0.61	1.342
140	66204-55170	WIRE HARNESS	1				0.285	0.627
150	66204-55182	WIRE HARNESS	1				0.2	0.44
160	66711-55190	WIRE HARNESS	1				0.017	0.0374
170	66204-55192	WIRE HARNESS	1				0.095	0.209
180	01202-50612	BOLT	2				0.005	0.011
190	15372-64602	ASSY REGULATOR	1				0.01	0.022
200	01053-50640	BOLT	2				0.011	0.0242
210	66704-55260	RUBBER	1				0.009	0.0198
220	02014-50060	NUT	2				0.003	0.0066
230	04013-50060	WASHER PLAIN	2				0	0
240	04512-50060	WASHER SPRING	2				0	0
250	15272-67580	CLAMP CORD	1				0.021	0.0462
260	55311-41120	SWITCH LIGHT	1				0.05	0.11
270	67401-99120	ASSY KNOB LIGHT SW.	1				0.005	0.011
280	35110-32420	PLUG	3				0.002	0.0044
290	13151-67160	PLUG STOP SWITCH	2	<=65175			0.01	0.022
290	38240-29570	PLUG	2	>=65176	↔		0.001	0.0022
300	01123-50818	BOLT	4				0.012	0.0264
310	04013-50080	WASHER PLAIN	4				0	0
320	66711-55470	CLAMP CORD	1				0.001	0.0022
330	66704-55510	BAND CORD	1				0.002	0.0044
340	66704-55310	METER TRACTOR	1				0.22	0.484
350	66611-55190	SUPPORT CORD	6				0.001	0.0022
360	66591-55520	ASSY FUSE RESERVE	1				0.004	0.0088
370	34670-33700	UNIT FLASHER	1				0.025	0.055
380	66204-55822	STAY UNIT	1				0.005	0.011
390	66706-55220	SUPPORT CORD	10				0.002	0.0044

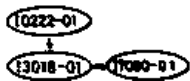
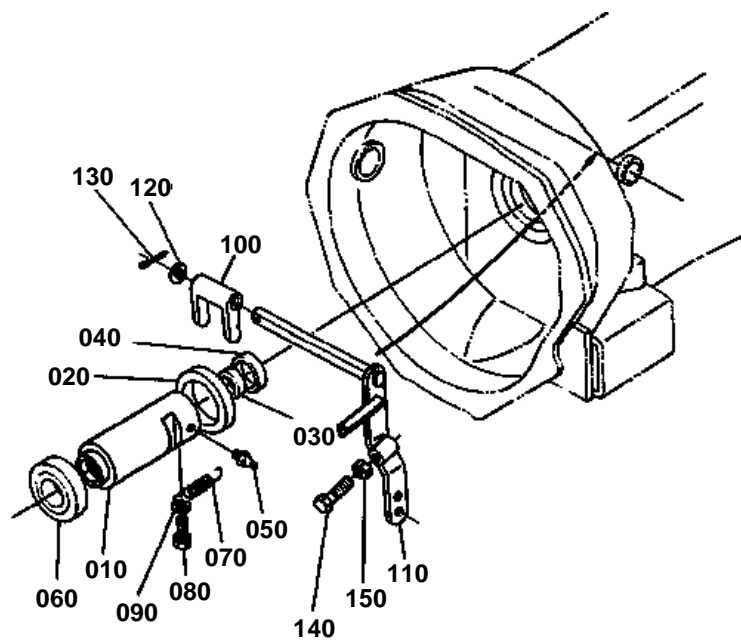



↔ Interchangeable; ≠ not interchangeable; ← new for old; → old for new

REF.No	Part No.	Description	Q'ty	S.No.	I/C	REMARKS	Weight (kgf)	Weight (lb)
010	66621-13314	HOLDER BEARING	1				0.63	1.386
020	66621-51420	SEAL OIL	1				0.011	0.0242
030	09030-20328	SEAL OIL	1				0.009	0.0198
040	09030-20357	SEAL OIL	1				0.009	0.0198
050	06613-10675	NIPPLE GREASE	1				0.003	0.0066
060	32150-14820	BEARING BALL	1				0.2	0.44
070	66611-13340	SPRING RELEASE	1				0.006	0.0132
080	01202-50610	BOLT	1				0.004	0.0088
090	04013-50060	WASHER PLAIN	1				0	0
100	66621-13350	FORK CLUTCH RELEASE	1				0.095	0.209
110	66204-13310	ROD CLUTCH	1				0.42	0.924
120	04011-50140	WASHER PLAIN	1				0.007	0.0154
130	05511-50320	PIN SPLIT	1				0.002	0.0044
140	66711-13320	BOLT ADJUSTING	1				0.028	0.0616
150	02116-50100	NUT	1				0.004	0.0088

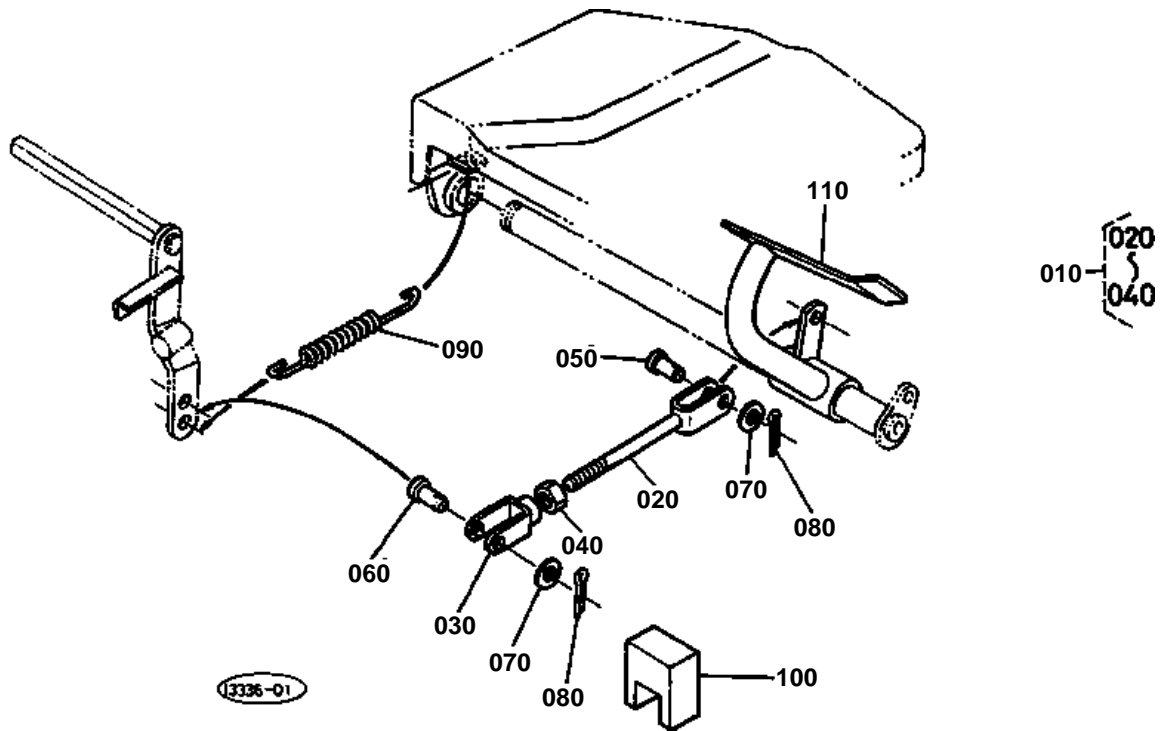



↔ Interchangeable; ≠ not interchangeable; ← new for old; → old for new

REF.No	Part No.	Description	Q'ty	S.No.	I/C	REMARKS	Weight (kgf)	Weight (lb)
010	66204-42100	ASSY ROD CLUTCH	1				0.182	0.4004
020	66204-42110	ROD CLUTCH	1				0.115	0.253
030	66621-43130	HOLDER	1				0.06	0.132
040	02112-50080	NUT	1				0.003	0.0066
050	05122-50822	PIN JOINT	1				0.01	0.022
060	05122-50825	PIN JOINT	1				0.011	0.0242
070	04012-50080	WASHER PLAIN	2				0.001	0.0022
080	05511-50215	PIN SPLIT	2				0.001	0.0022
090	66204-43250	SPRING RETURN	1				0.13	0.286
100	66711-42150	SPACER PEDAL	1				0.027	0.0594
110	66711-42120	PEDAL CLUTCH	1				0.926	2.0372

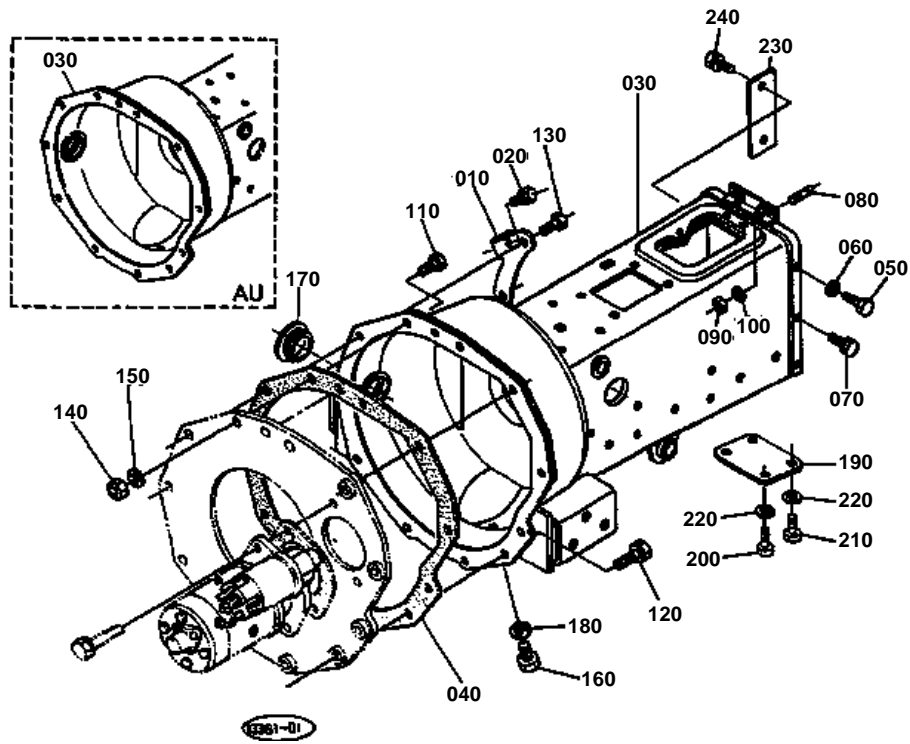



CLUTCH HOUSING TRACTOR S.No.:B7100HST-D >=60164 B7100HST-E >=20025

↔ Interchangeable; ≠ not interchangeable; ← new for old; → old for new

REF.No	Part No.	Description	Q'ty	S.No.	I/C	REMARKS	Weight (kgf)	Weight (lb)
010	66704-36150	HOLDER	1				0.06	0.132
020	01123-50814	BOLT	1				0	0
030	66904-51100	HOUSING CLUTCH	1	<=70885		[A] [CA]	21	46.2
030	66904-51103	HOUSING FRAME CLUTCH	1	>=70886	←	[A] [CA]	21.2	46.64
030	66204-51100	HOUSING FRAME CLUTCH	1			[AU]	18.7	41.14
040	66621-51410	GASKET	1				0	0
050	66204-51150	BOLT REAMER	4				0	0
060	04512-50140	WASHER SPRING	4				0	0
070	01153-51230	BOLT	2				0.036	0.0792
080	01555-51220	STUD	2				0.034	0.0748
090	02174-50120	NUT	2				0.01	0.022
100	04512-50120	WASHER SPRING	4				0.003	0.0066
110	01153-50825	BOLT	1				0.012	0.0264
120	01123-50825	BOLT	8				0.013	0.0286
130	01153-50828	BOLT	2				0.014	0.0308
140	02114-50080	NUT	3				0.005	0.011
150	04512-50080	WASHER SPRING	3				0.001	0.0022
160	06331-35010	PLUG	1				0.012	0.0264
170	66704-51190	COVER TIMING HOLE	1				0.009	0.0198
180	04717-01000	WASHER WITH RUBBER	1				0.001	0.0022
190	66204-51180	PLATE JOINT	1				0.44	0.968
200	01173-51225	BOLT	2				0.033	0.0726
210	01153-51230	BOLT	2				0.036	0.0792
220	04512-50120	WASHER SPRING	4				0.003	0.0066
230	66204-51190	COVER	1				0.075	0.165
240	01123-50818	BOLT	2				0.012	0.0264

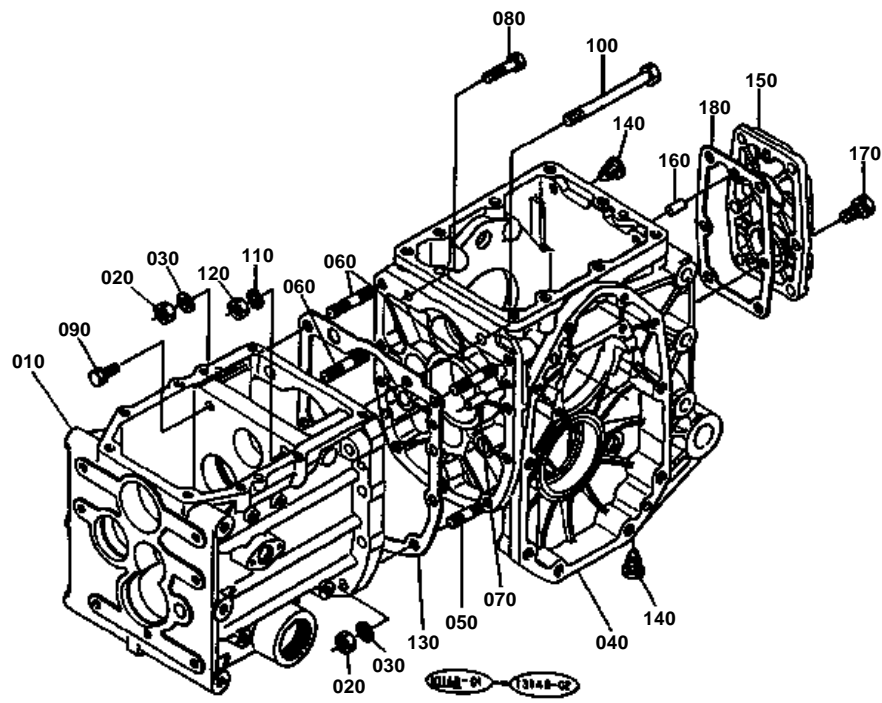

150 65706-1221-0

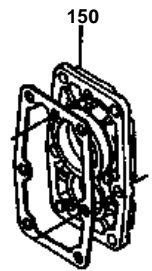



↔ Interchangeable; ≠ not interchangeable; ← new for old; → old for new

REF.No	Part No.	Description	Q'ty	S.No.	I/C	REMARKS	Weight (kgf)	Weight (lb)
010	66204-11119	CASE TRANSMISSION	1				19	41.8
020	02176-50100	NUT	9				0.005	0.011
030	04512-50100	WASHER SPRING	9				0	0
040	66611-11173	CASE GEAR	1	<=66628			0	0
040	66611-11174	CASE GEAR	1	>=66629	←		8.5	18.7
050	01555-51035	STUD	6				0.029	0.0638
060	01555-51050	STUD	3				0.038	0.0836
070	66611-11160	PIN KNOCK	2				0.01	0.022
080	01123-50838	BOLT	1				0.02	0.044
090	01123-50825	BOLT	1				0.013	0.0286
100	66204-11140	BOLT	1				0.097	0.2134
110	04512-50100	WASHER SPRING	1				0	0
120	02118-50100	NUT	1				0.005	0.011
130	66611-11130	GASKET	1				0	0
140	67211-11140	PLUG	4				0.001	0.0022
150	66706-12210	COVER REAR	1	<=66299			1.21	2.662
150	67211-12212	COVER REAR	1	>=66300	←		1.45	3.19
160	05012-00816	PIN STRAIGHT	1				0.007	0.0154
170	01123-51025	BOLT	6				0.02	0.044
180	66611-12220	GASKET	1				0	0

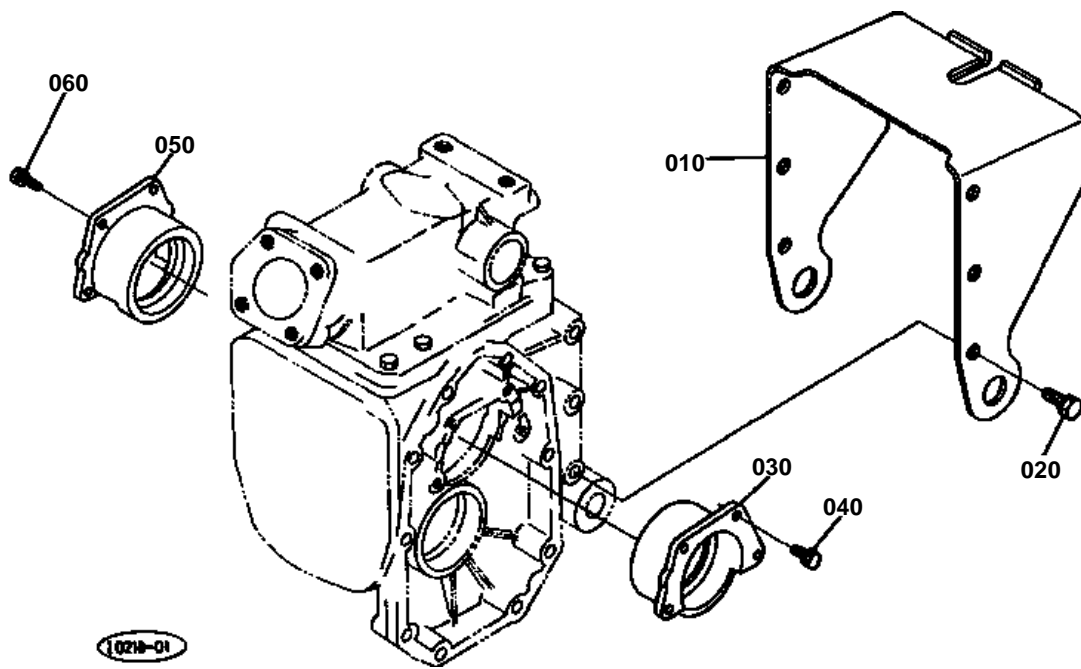



↔ Interchangeable; ≠ not interchangeable; ← new for old; → old for new

REF.No	Part No.	Description	Q'ty	S.No.	I/C	REMARKS	Weight (kgf)	Weight (lb)
010	66704-11214	COVER PTO	1				1.5	3.3
020	01123-51235	BOLT	6				0.041	0.0902
030	66611-11510	HOLDER DIFF.BRG.LH	1				0.78	1.716
040	01123-50822	BOLT	4				0.012	0.0264
050	66611-11812	HOLDER DIFF.BRG.RH	1				0.72	1.584
060	01123-50822	BOLT	4				0.012	0.0264

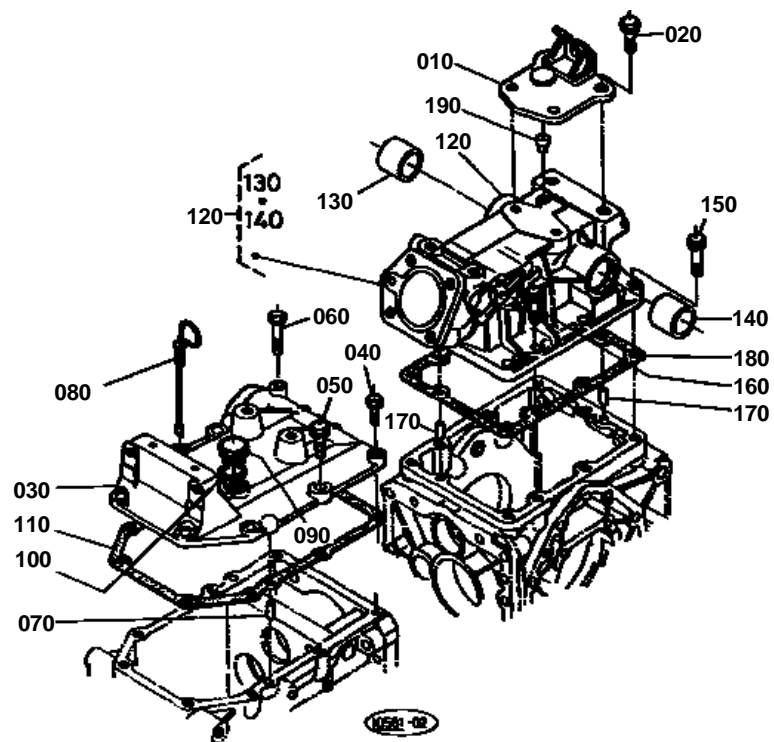



↔ Interchangeable; ≠ not interchangeable; ← new for old; → old for new

REF.No	Part No.	Description	Q'ty	S.No.	I/C	REMARKS	Weight (kgf)	Weight (lb)
010	66611-11910	BRACKET CHAIN	1				0.607	1.3354
020	01123-51230	BOLT	2				0.04	0.088
030	66204-12410	COVER UPPER FRONT	1				3.6	7.92
040	01123-50828	BOLT	1				0.014	0.0308
050	01123-51035	BOLT	6				0.025	0.055
060	01123-50845	BOLT	1				0.02	0.044
070	05012-00816	PIN STRAIGHT	2				0.007	0.0154
080	67711-12420	GAUGE OIL	1				0.014	0.0308
090	66591-11460	CAP	1				0.016	0.0352
100	04713-00400	GASKET	1				0.001	0.0022
110	66204-12450	GASKET	1				0	0
120	67211-12500	ASSY COVER REAR	1				4.32	9.504
130	66591-36710	BUSH	1				0.049	0.1078
140	66591-36720	BUSH	1				0.044	0.0968
150	01123-51040	BOLT	3				0.03	0.066
160	01123-51035	BOLT	6				0.025	0.055
170	05012-00816	PIN STRAIGHT	2				0.007	0.0154
180	66611-12520	GASKET	1				0	0
190	66591-11350	BREATHER	1	<=64107			0.002	0.0044
190	67156-12533	BREATHER	1	>=64108	↔		0.002	0.0044

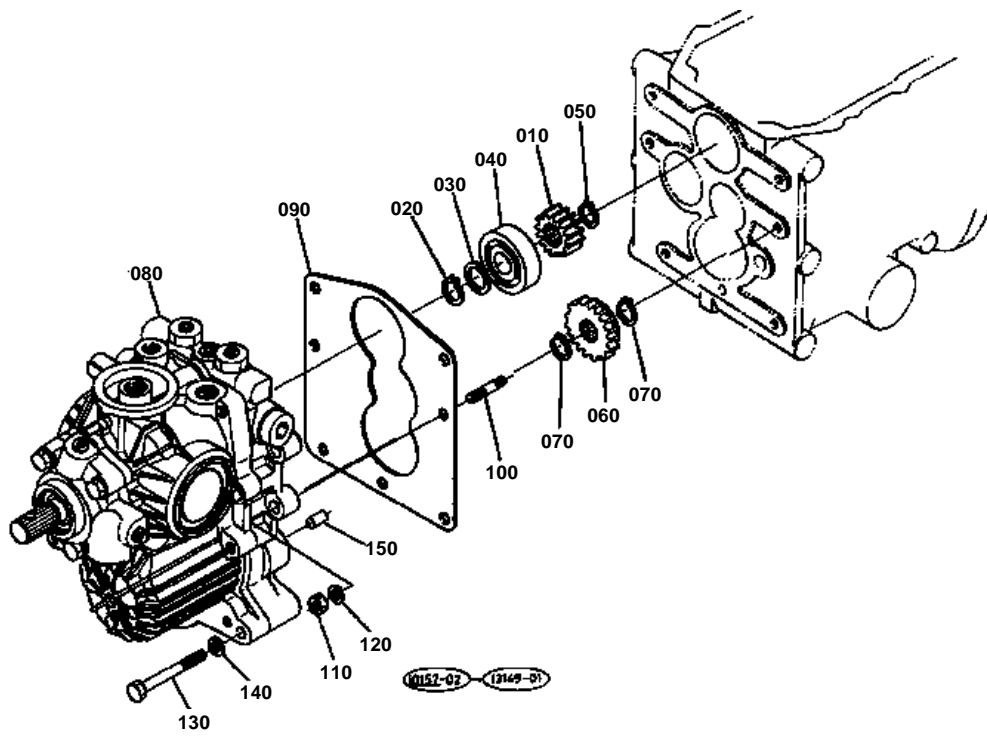



↔ Interchangeable; ≠ not interchangeable; ← new for old; → old for new

REF.No	Part No.	Description	Q'ty	S.No.	I/C	REMARKS	Weight (kgf)	Weight (lb)
010	66204-14120	GEAR	1			13T	0.085	0.187
020	04612-00200	CIR CLIP EXTERNAL	1				0.001	0.0022
030	66711-14880	COLLAR BACK SHAFT	1				0	0
040	08101-06304	BEARING BALL	1				0.146	0.3212
050	04612-00190	CIR CLIP EXTERNAL	1				0.001	0.0022
060	66204-14152	GEAR	1			16T	0.15	0.33
070	04612-00200	CIR CLIP EXTERNAL	2				0.001	0.0022
080	66415-11600	ASSY HST	1			REFER TO L.No.0C08-L0 FOR COMPONENTS.	13.5	29.7
090	66204-36180	GASKET HST	1				0	0
100	01555-51035	STUD	4				0.029	0.0638
110	02118-50100	NUT	4				0.005	0.011
120	04512-50100	WASHER SPRING	4				0	0
130	01153-51075	BOLT	2				0.045	0.099
140	04512-50100	WASHER SPRING	2				0	0
150	05012-00816	PIN STRAIGHT	1				0.007	0.0154

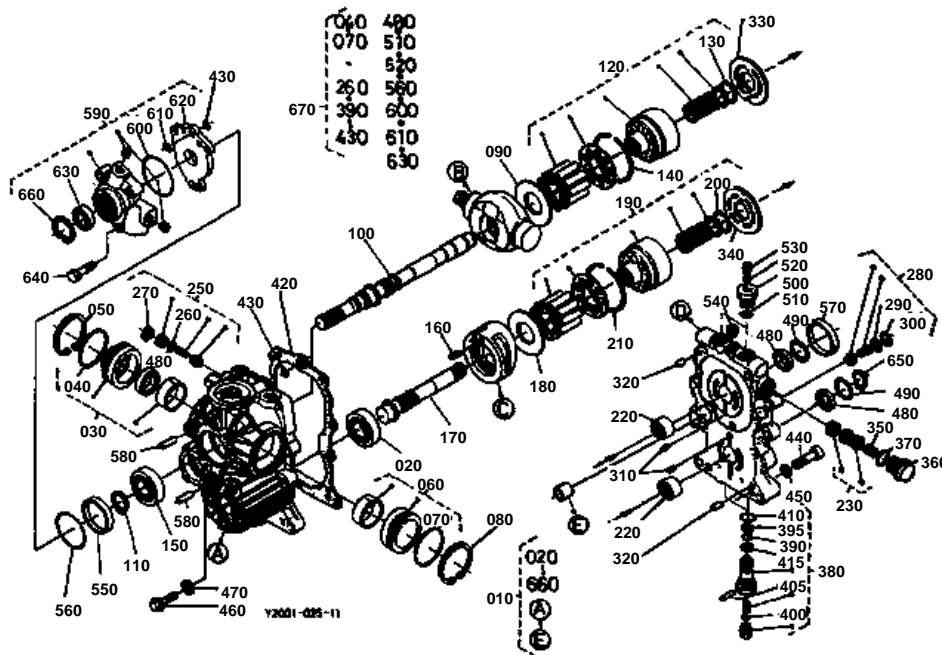

230 66415-8380-0
240 04810-00050

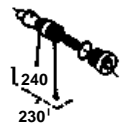

680 06311-25030
690 04810-00140





↔ Interchangeable; ≠ not interchangeable; ← new for old; → old for new

REF.No	Part No.	Description	Q'ty	S.No.	I/C	REMARKS	Weight (kgf)	Weight (lb)
010	66415-11600	ASSY HST	1				13.5	29.7
020	66415-39340	BEARING BALL	1				0.05	0.11
030	66415-83300	ASSY COVER A	1				0.47	1.034
040	04811-50550	O RING	1				0.002	0.0044
050	04611-00620	CIR CLIP INTERNAL	1				0.011	0.0242
060	66415-83400	ASSY COVER B	1				0.47	1.034
070	04811-50550	O RING	1				0.002	0.0044
080	04611-00620	CIR CLIP INTERNAL	1				0.011	0.0242
090	66415-39150	PLATE THRUST	1				0.05	0.11
100	66415-39310	SHAFT (P)	1	<=65623			0.5	1.1
100	66415-39315	SHAFT (P)	1	>=65624	≠		0.75	1.65
110	04612-00250	CIR CLIP EXTERNAL	1				0.002	0.0044
120	66415-83100	ASSY BLOCK CYL.	1				1.13	2.486
130	66415-39470	CIR CLIP INTERNAL	1				0.02	0.044
140	66415-39270	RING SNAP	1				0.02	0.044
150	66415-39340	BEARING BALL	1				0.05	0.11
160	05012-00616	PIN STRAIGHT	1	<=68002			0.004	0.0088
160	05411-00825	PIN SPRING	1	>=68003	≠		0.006	0.0132
170	66415-39320	SHAFT (M)	1	<=68002			0.5	1.1
170	66415-39323	SHAFT (M)	1	>=68003	≠		0.42	0.924
180	66415-39150	PLATE THRUST	1				0.05	0.11
190	66415-83100	ASSY BLOCK CYL.	1				1.13	2.486
200	66415-39470	CIR CLIP INTERNAL	1				0.02	0.044
210	66415-39270	RING SNAP	1				0.02	0.044
220	66415-39750	BEARING NEEDLE	2				0.02	0.044
230	66415-83800	ASSY VALVE RELIEF	2	<=64107			0.06	0.132
230	66415-83802	ASSY VALVE RELIEF	2	>=64108	≠		0.03	0.066
240	04810-00050	O RING	2	<=64107			0.001	0.0022
250	66415-83700	ASSY VALVE RELIEF	1				0.001	0.0022
260	04810-00120	O RING	1				0.001	0.0022
270	04611-00170	CIR CLIP INTERNAL	1				0.001	0.0022
280	66415-84400	ASSY VALVE RELIEF	1				0.05	0.11
290	04013-50080	WASHER PLAIN	1	<=63885			0	0
290	66363-39740	WASHER	1	>=63886	↔		0.001	0.0022
300	04611-00180	CIR CLIP INTERNAL	1				0.001	0.0022
310	05012-00414	PIN STRAIGHT	2	<=65847			0.002	0.0044
310	05411-00416	PIN SPRING	2	>=65848	↔		0.001	0.0022
320	05012-00612	PIN STRAIGHT	2	<=64107			0.003	0.0066
320	05012-00610	PIN STRAIGHT	2	>=64108	↔		0.003	0.0066
330	66415-39910	PLATE VALVE (P)	1				0.03	0.066
340	66415-39920	PLATE VALVE (M)	1				0.02	0.044
350	66363-39520	SPRING	2				0.001	0.0022
360	66415-39590	PLUG	2				0.03	0.066
370	04811-00180	O RING	2				0.001	0.0022
380	66363-83600	ASSY VALVE NEUTRAL	2				0.1	0.22
390	04810-00120	O RING	2				0.001	0.0022
395	66363-39630	RING BACK UP	2				0.001	0.0022
400	04810-00100	O RING	2				0.001	0.0022
405	05411-00325	PIN SPRING	2				0.001	0.0022
410	04811-00180	O RING	2				0.001	0.0022
415	04013-50060	WASHER PLAIN	2				0	0
420	66415-39550	GASKET	1				0.01	0.022
430	04810-00100	O RING	2				0.001	0.0022
440	66415-39740	BOLT HEX-SOC-HD	8				0.034	0.0748
450	66415-39560	WASHER SPRING	8				0.003	0.0066
460	01754-50835	BOLT FLANGE	1	>=68003			0.019	0.0418
470	04714-00080	GASKET	1	>=68003			0.001	0.0022
480	66363-39560	SEAL OIL	3				0.01	0.022
490	04611-00350	CIR CLIP INTERNAL	2				0.003	0.0066



↔ Interchangeable; ≠ not interchangeable; ← new for old; → old for new

REF.No	Part No.	Description	Q'ty	S.No.	I/C	REMARKS	Weight (kgf)	Weight (lb)
500	66415-39520	PLUG	2				0.033	0.0726
510	04810-00140	O RING	2				0.001	0.0022
520	04714-00040	GASKET	2				0.001	0.0022
530	66415-39530	SCREW	2				0.005	0.011
540	15521-96030	PLUG	2				0.007	0.0154
550	66415-39540	COLLAR	1				0.025	0.055
560	04811-06530	O RING	1				0.001	0.0022
570	66415-39430	COLLAR	1				0.07	0.154
580	05012-00625	PIN STRAIGHT	2	<=68002			0.006	0.0132
580	05012-00620	PIN STRAIGHT	2	>=68003	≠		0.005	0.011
590	66415-83500	ASSY PUMP CHARGE	1				0	0
600	04811-06630	O RING	1				0.001	0.0022
610	04810-00120	O RING	1				0.001	0.0022
620	66415-39640	COVER CHARGE PUMP	1				0.05	0.11
630	66363-39560	SEAL OIL	1				0.01	0.022
640	01123-50840	BOLT	3				0.018	0.0396
650	04612-00200	CIR CLIP EXTERNAL	1				0.001	0.0022
660	04611-00350	CIR CLIP INTERNAL	1				0.003	0.0066
670	66415-84900	KIT SEAL	1				0.05	0.11
680	06311-25030	PLUG	1	<=68002			0.051	0.1122
690	04810-00140	O RING	1	<=68002			0.001	0.0022

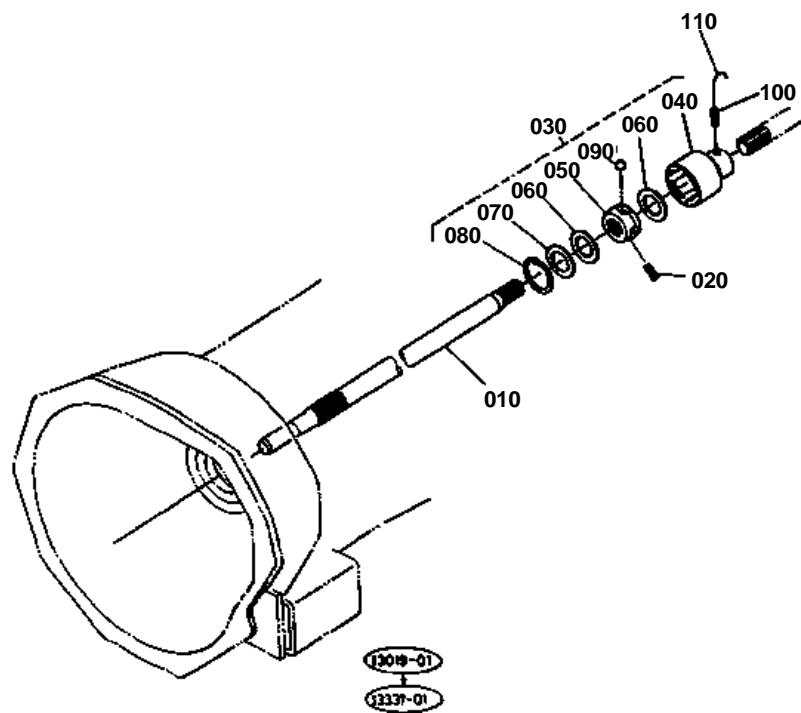



↔ Interchangeable; ≠ not interchangeable; ← new for old; → old for new

REF.No	Part No.	Description	Q'ty	S.No.	I/C	REMARKS	Weight (kgf)	Weight (lb)
010	66204-14114	SHAFT PROPELLER	1				1.1	2.42
020	05411-00628	PIN SPRING	1				0.004	0.0088
030	67211-14122	ASSY JOINT BALL	1				0.3	0.66
040	67111-13710	COUPLING BALL OUTER	1				0.225	0.495
050	67211-14133	COUPLING BALL INNER	1				0.075	0.165
060	67111-13730	GASKET BALL JOINT	2				0.002	0.0044
070	67111-13740	SUPPORT GASKET	1				0.004	0.0088
080	04611-00350	CIR CLIP INTERNAL	1				0.003	0.0066
090	07715-00803	BALL	4				0.004	0.0088
100	05411-00640	PIN SPRING	1				0.006	0.0132
110	99999-99999	WIRE	1			OBTAINED LOCALLY	0	0

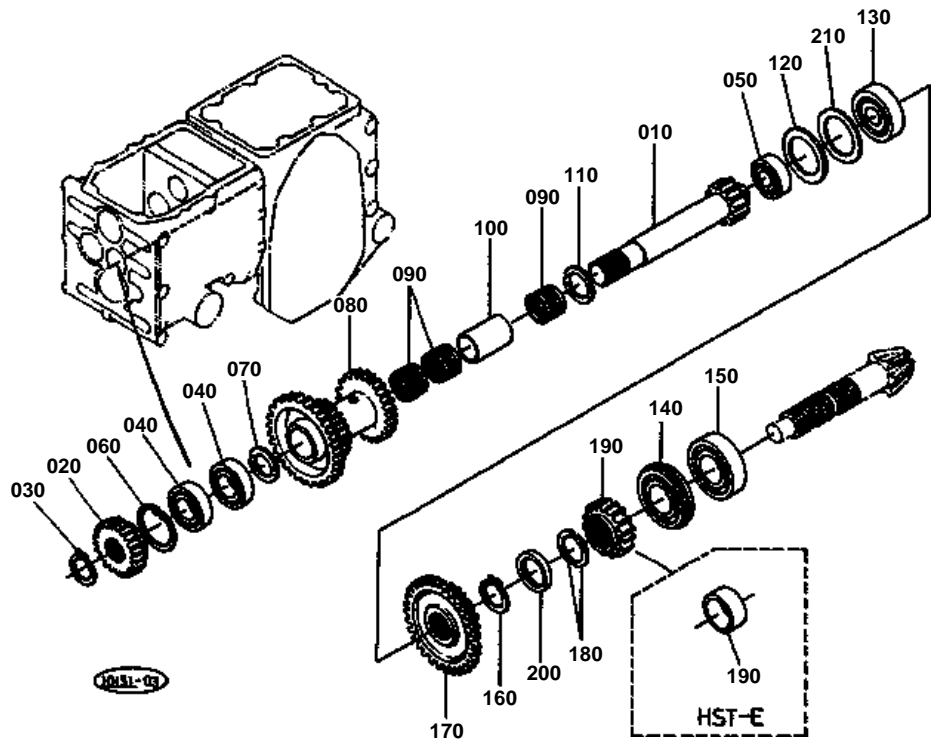



↔ Interchangeable; ≠ not interchangeable; ← new for old; → old for new

REF.No	Part No.	Description	Q'ty	S.No.	I/C	REMARKS	Weight (kgf)	Weight (lb)
010	66204-14212	SHAFT	1				0.49	1.078
020	66204-14220	GEAR	1			14T	0.13	0.286
030	04612-00200	CIR CLIP EXTERNAL	1				0.001	0.0022
040	08101-06204	BEARING BALL	2				0.102	0.2244
050	67311-14270	BEARING BALL	1				0.09	0.198
060	04611-00470	CIR CLIP INTERNAL	1				0.006	0.0132
070	67061-14220	COLLAR THRUST FRONT	1				0.01	0.022
080	66204-14232	GEAR	1			30-14-18T	0.94	2.068
090	67061-14240	BEARING NEEDLE	3				0.03	0.066
100	66711-14872	COLLAR	1				0.05	0.11
110	67061-14260	COLLAR THRUST REAR	1				0.01	0.022
120	66591-14720	SPACER	1				0.002	0.0044
130	08221-07303	BEARING BALL	1				0.116	0.2552
140	67211-14620	BEARING BALL	1				0.23	0.506
150	38450-21980	BEARING BALL	1				0.225	0.495
160	04612-00250	CIR CLIP EXTERNAL	1				0.002	0.0044
170	66204-14630	GEAR	1			20-12T	0.31	0.682
180	67156-14640	COLLAR STOP	2				0.005	0.011
190	66611-14650	GEAR	1			16T	0.104	0.2288
200	67156-14660	COLLAR	1				0.01	0.022
210	66611-14670	SHIM	1			1.4MM	0.008	0.0176
210	66611-14680	SHIM	1			1.8MM	0.01	0.022
210	66611-14690	SHIM	1			0.2MM	0.001	0.0022

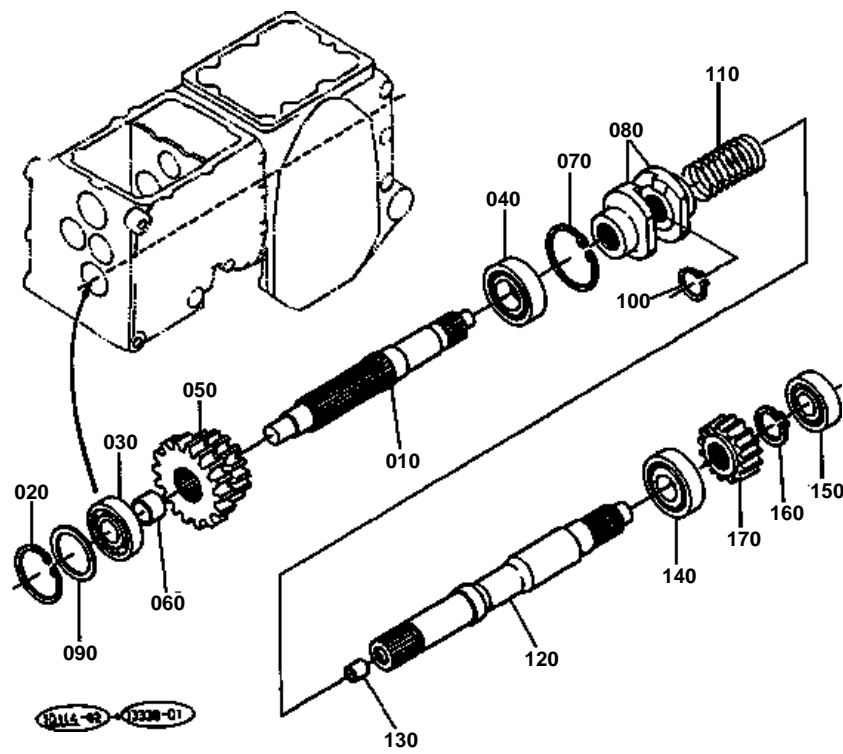



↔ Interchangeable; ≠ not interchangeable; ← new for old; → old for new

REF.No	Part No.	Description	Q'ty	S.No.	I/C	REMARKS	Weight (kgf)	Weight (lb)
010	66204-14310	SHAFT	1				0.7	1.54
020	04611-00470	CIR CLIP INTERNAL	1				0.006	0.0132
030	08101-06303	BEARING BALL	1				0.112	0.2464
040	08101-06205	BEARING BALL	1				0.14	0.308
050	66204-14323	GEAR	1			21-17T	0.57	1.254
060	66204-14330	COLLAR SHAFT	1				0.03	0.066
070	04611-00520	CIR CLIP INTERNAL	1				0.009	0.0198
080	66706-14380	CAM ONE WAY CLUTCH	2				0.198	0.4356
090	62131-14170	SHIM	1			0.5MM	0.002	0.0044
100	04612-00220	CIR CLIP EXTERNAL	1				0.001	0.0022
110	66706-14390	SPRING ONE-WAY	1				0.045	0.099
120	66706-14510	SHAFT	1				0	0
130	66706-14520	BUSH	1				0.004	0.0088
140	67121-56760	BEARING BALL	1	<=65015			0	0
140	67121-56770	BEARING BALL	1	>=65016	←		0.127	0.2794
150	67311-14530	BEARING BALL	1				0.11	0.242
160	04612-00250	CIR CLIP EXTERNAL	1				0.002	0.0044
170	66204-14510	GEAR	1			14T	0.135	0.297

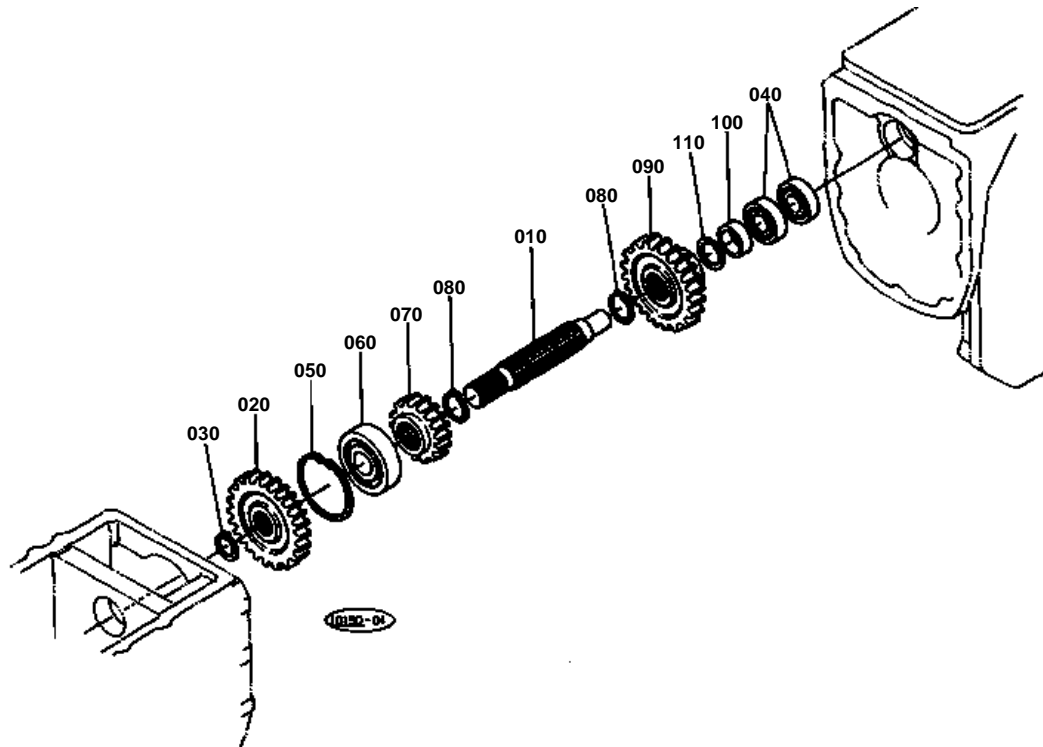



↔ Interchangeable; ≠ not interchangeable; ← new for old; → old for new

REF.No	Part No.	Description	Q'ty	S.No.	I/C	REMARKS	Weight (kgf)	Weight (lb)
010	66204-14410	SHAFT	1				0.35	0.77
020	66204-14420	GEAR	1			24T	0.31	0.682
030	04612-00200	CIR CLIP EXTERNAL	1				0.001	0.0022
040	08101-06202	BEARING BALL	2				0.044	0.0968
050	04611-00520	CIR CLIP INTERNAL	1				0.009	0.0198
060	08101-06304	BEARING BALL	1				0.146	0.3212
070	66204-14430	GEAR	1			15T	0.145	0.319
080	04612-00220	CIR CLIP EXTERNAL	2				0.001	0.0022
090	66204-14440	GEAR REAR SHAFT	1			23T	0.35	0.77
100	66611-14470	COLLAR	1				0.019	0.0418
110	66204-81410	SHIM A	1			0.6MM	0.001	0.0022
110	66204-81420	SHIM B	1			0.3MM	0.001	0.0022

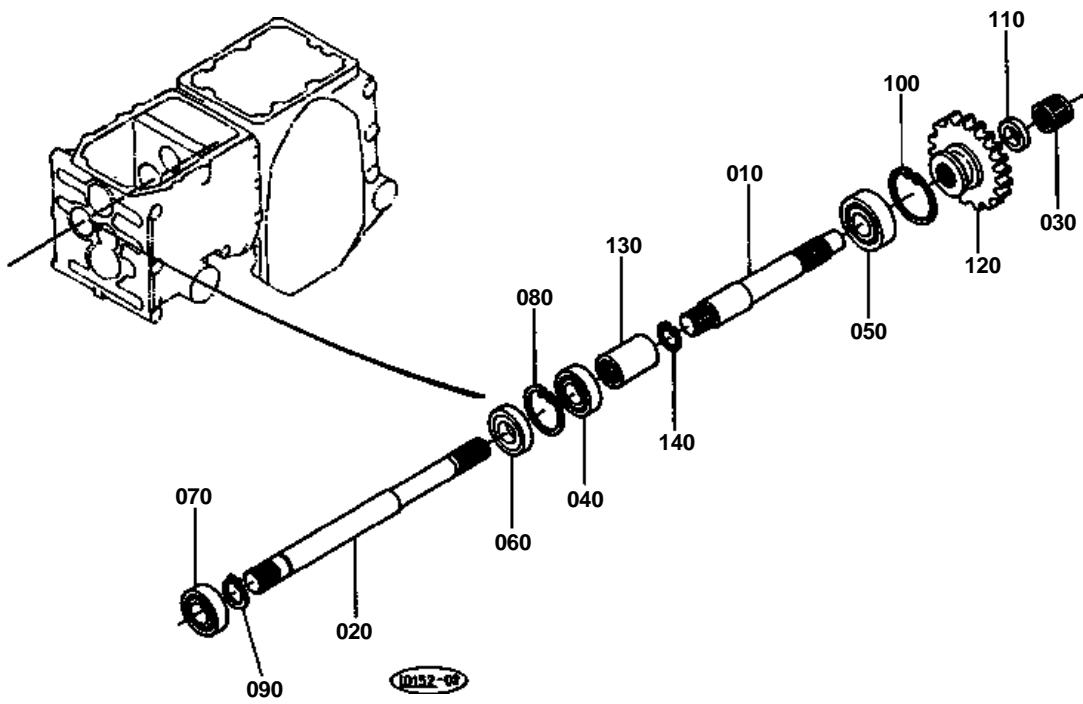



↔ Interchangeable; ≠ not interchangeable; ← new for old; → old for new

REF.No	Part No.	Description	Q'ty	S.No.	I/C	REMARKS	Weight (kgf)	Weight (lb)
010	66204-14830	SHAFT FRONT DRIVE	1				0.46	1.012
020	66204-14810	SHAFT FRONT DRIVE	1				0.67	1.474
030	66611-14820	BEARING NEEDLE	1				0	0
040	67311-14820	BEARING BALL	1				0.07	0.154
050	08101-06204	BEARING BALL	1				0.102	0.2244
060	09500-20428	SEAL OIL	1				0.012	0.0264
070	08141-06004	BEARING BALL	1				0.064	0.1408
080	04611-00420	CIR CLIP INTERNAL	1				0.006	0.0132
090	04612-00200	CIR CLIP EXTERNAL	1				0.001	0.0022
100	04611-00470	CIR CLIP INTERNAL	1				0.006	0.0132
110	66611-14830	COLLAR	1				0.016	0.0352
120	66611-14840	GEAR	1			24T	0.26	0.572
130	66204-14820	JOINT FRONT DRIVE	1				0.12	0.264
140	04611-00180	CIR CLIP INTERNAL	1				0.001	0.0022

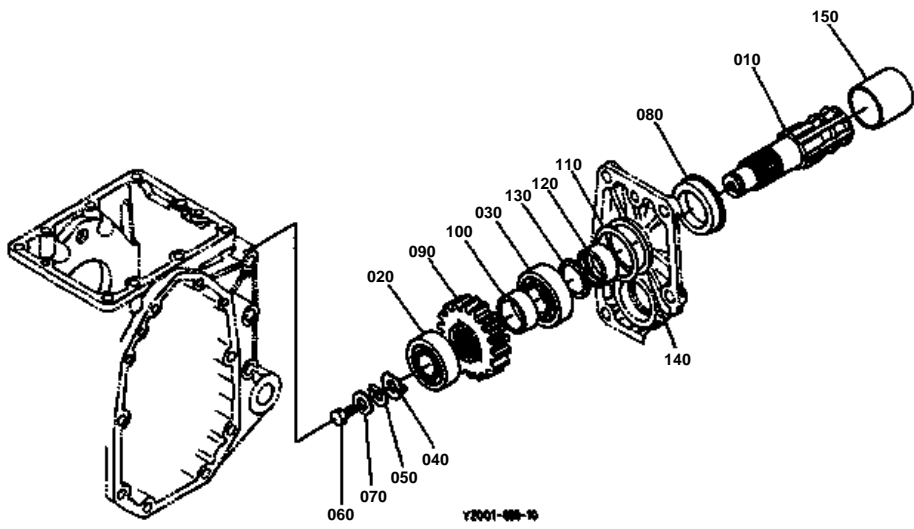

010 66204-1471-0





↔ Interchangeable; ≠ not interchangeable; ← new for old; → old for new

REF.No	Part No.	Description	Q'ty	S.No.	I/C	REMARKS	Weight (kgf)	Weight (lb)
010	66204-14710	SHAFT PTO	1	<=65015			0	0
010	66706-14710	SHAFT PTO	1	>=65016	↔		0.61	1.342
020	08711-30204	BEARING TAPER-ROLLER	1				0.116	0.2552
030	08711-30205	BEARING TAPER-ROLLER	1				0.148	0.3256
040	66704-14720	WASHER	1				0.009	0.0198
050	63753-32430	WASHER LOCK	1				0.001	0.0022
060	66704-14730	BOLT	1				0.012	0.0264
070	04012-50080	WASHER PLAIN	1				0.001	0.0022
080	09180-35488	SEAL OIL	1				0.019	0.0418
090	66204-14790	GEAR	1			21T	0.465	1.023
100	66706-14740	COLLAR PTO	1				0.03	0.066
110	66706-14782	COLLAR	1				0.006	0.0132
120	66611-14730	BUSH	1				0.042	0.0924
130	66611-14740	COLLAR PTO	1				0.004	0.0088
140	66611-14750	SHIM PTO	1			0.5MM	0.002	0.0044
140	66611-14760	SHIM PTO	1			0.4MM	0.002	0.0044
140	66611-14770	SHIM PTO	1			0.3MM	0.001	0.0022
150	66706-14810	COVER PTO	1				0.024	0.0528

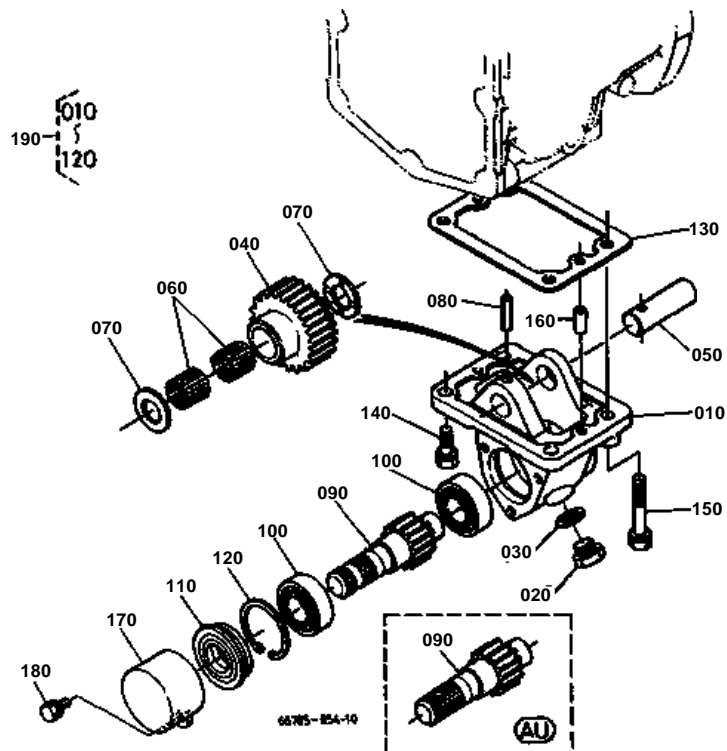



↔ Interchangeable; ≠ not interchangeable; ← new for old; → old for new

REF.No	Part No.	Description	Q'ty	S.No.	I/C	REMARKS	Weight (kgf)	Weight (lb)
010	67061-21215	CASE DRIVE MID PTO	1				0.78	1.716
020	06331-35016	PLUG	1				0.04	0.088
030	04717-01600	WASHER WITH RUBBER	1				0.003	0.0066
040	67061-21223	GEAR	1			24T	0.44	0.968
050	67061-21232	SHAFT IDLE	1				0.2	0.44
060	67061-21270	BEARING NEEDLE	2				0.03	0.066
070	96380-25140	COLLAR SHAFT	2				0.014	0.0308
080	05411-00618	PIN SPRING	1				0.003	0.0066
090	66417-21240	GEAR-SHAFT	1			11T [A] [CA]	0.54	1.188
090	67061-21242	GEAR-SHAFT	1			11T [AU]	0.52	1.144
100	08101-06205	BEARING BALL	2				0.14	0.308
110	32430-25540	SEAL OIL MID PTO	1				0.04	0.088
120	04611-00520	CIR CLIP INTERNAL	1				0.009	0.0198
130	66204-21220	GASKET	1				0	0
140	01123-51028	BOLT	2				0.025	0.055
150	01123-51040	BOLT	2				0.03	0.066
160	05012-00816	PIN STRAIGHT	2				0.007	0.0154
170	66204-21250	COVER MID-PTO	1				0.07	0.154
180	01123-50816	BOLT	1				0.011	0.0242
190	66417-21200	KIT PTO MID	1			[A] [CA]	2.3	5.06
190	67061-21205	ASSY PTO MID	1			[AU]	2.8	6.16

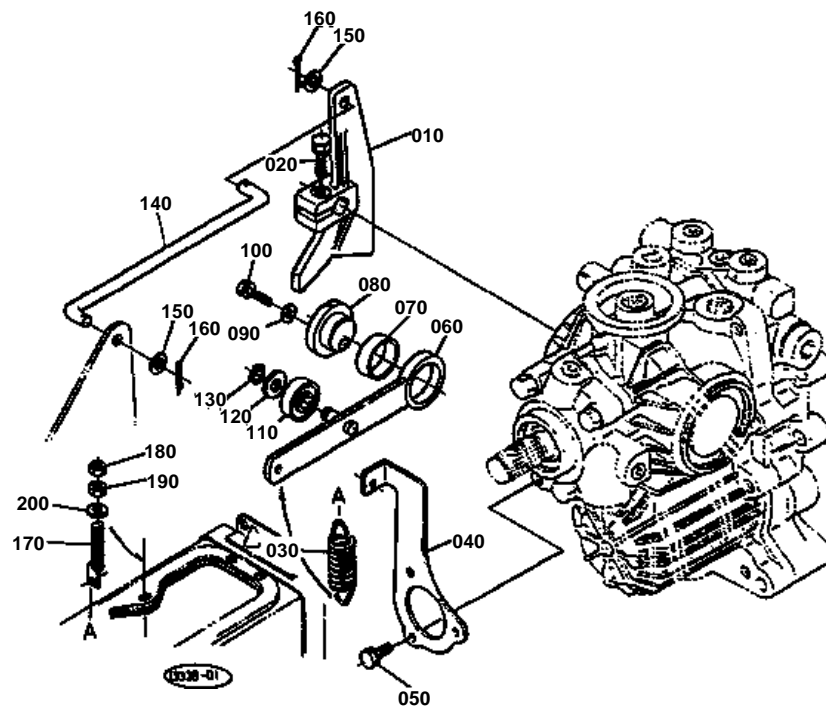



↔ Interchangeable; ≠ not interchangeable; ← new for old; → old for new

REF.No	Part No.	Description	Q'ty	S.No.	I/C	REMARKS	Weight (kgf)	Weight (lb)
010	66204-43310	HOLDER NEUTRAL	1				0.28	0.616
020	01123-50828	BOLT	1				0.014	0.0308
030	66204-43323	SPRING	1				0.055	0.121
040	66204-43330	HOLDER SPRING	1				0.095	0.209
050	01202-50614	BOLT	3				0.006	0.0132
060	66204-43343	ARM NEUTRAL HOLDER	1				0.13	0.286
070	66204-43572	BUSH	1				0.003	0.0066
080	66204-43352	SHAFT HOLDER	1				0.072	0.1584
090	04012-50080	WASHER PLAIN	1				0.001	0.0022
100	01123-50832	BOLT	1				0.016	0.0352
110	08121-06000	BEARING BALL	1				0.02	0.044
120	04011-50100	WASHER PLAIN	1				0.002	0.0044
130	04612-00100	CIR CLIP EXTERNAL	1				0.001	0.0022
140	66204-43363	ROD SPEED CHANGE	1				0.08	0.176
150	04012-50080	WASHER PLAIN	2				0.001	0.0022
160	05511-50215	PIN SPLIT	2				0.001	0.0022
170	66204-43650	BOLT SPRING ADJUST	1				0.07	0.154
180	02172-50120	NUT	1				0.01	0.022
190	02174-50120	NUT	1				0.01	0.022
200	04011-50120	WASHER PLAIN	1				0.005	0.011

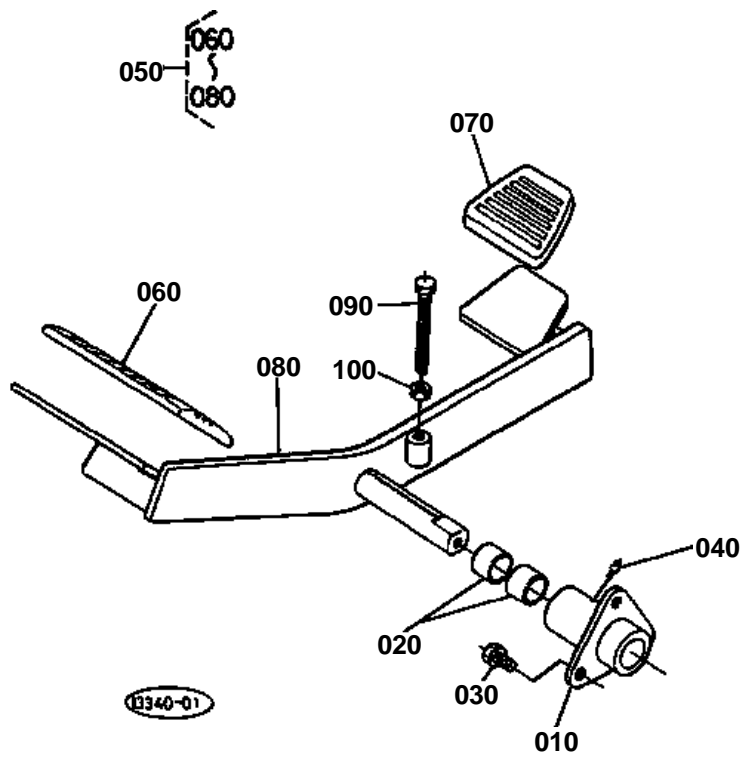



↔ Interchangeable; ≠ not interchangeable; ← new for old; → old for new

REF.No	Part No.	Description	Q'ty	S.No.	I/C	REMARKS	Weight (kgf)	Weight (lb)
010	66204-43370	HOLDER PEDAL	1				0.25	0.55
020	08511-01815	BUSH	2				0.007	0.0154
030	01123-50818	BOLT	3				0.012	0.0264
040	67211-42940	NIPPLE GREASE	1				0.001	0.0022
050	66204-43300	ASSY PEDAL S-CHANGE	1				1.2	2.64
060	66204-43390	COVER PEDAL FRONT	1				0.06	0.132
070	66204-43410	COVER PEDAL REAR	1				0.06	0.132
080	66204-43380	PEDAL SPEED CHANGE	1				1.1	2.42
090	01155-50875	BOLT	1				0	0
100	02114-50080	NUT	1				0.005	0.011

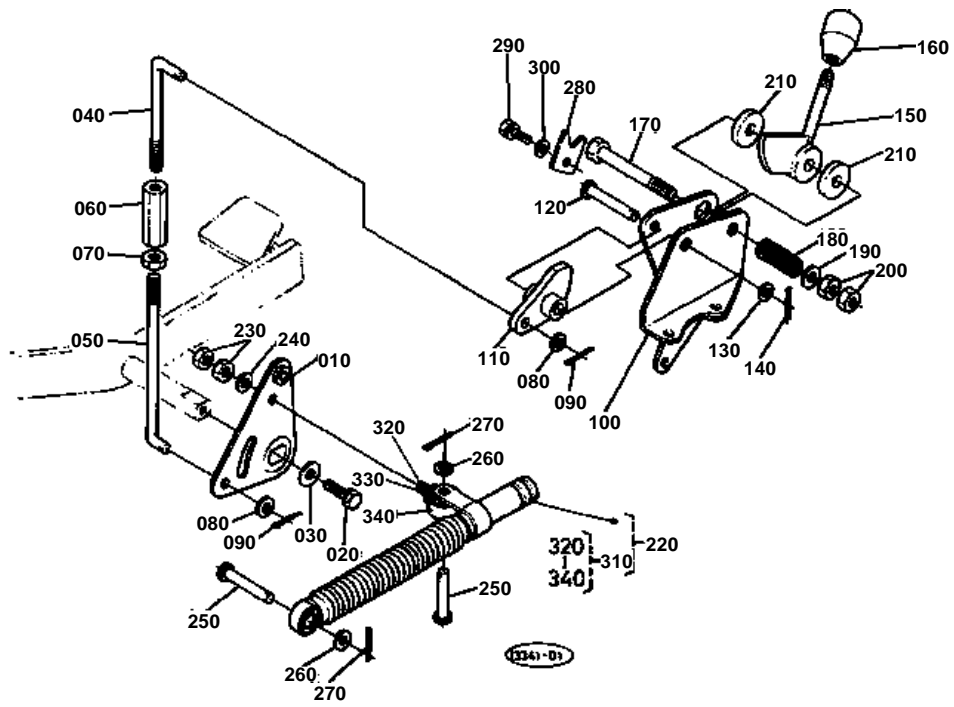



↔ Interchangeable; ≠ not interchangeable; ← new for old; → old for new

REF.No	Part No.	Description	Q'ty	S.No.	I/C	REMARKS	Weight (kgf)	Weight (lb)
010	66204-43424	PLATE SPEED CHANGE	1				0.2	0.44
020	01123-50816	BOLT	1				0.011	0.0242
030	04015-50080	WASHER PLAIN	1				0	0
040	66204-43430	ROD CHECK UPPER	1				0.04	0.088
050	66204-43440	ROD CHECK UNDER	1				0.13	0.286
060	66591-42410	TURNBUCKLE	1				0.046	0.1012
070	02112-50080	NUT	1				0.003	0.0066
080	04012-50080	WASHER PLAIN	2				0.001	0.0022
090	05511-50215	PIN SPLIT	2				0.001	0.0022
100	66204-43450	PLATE CHECK	1				0.47	1.034
110	66204-43460	INTERLOCKER	1				0.105	0.231
120	05122-51045	PIN JOINT	1				0	0
130	04013-50100	WASHER PLAIN	1				0	0
140	05511-50318	PIN SPLIT	1				0.001	0.0022
150	66204-43470	LEVER CHECK	1				0.19	0.418
160	63763-42260	GRIP B	1				0.021	0.0462
170	66204-43480	BOLT	1				0.06	0.132
180	66204-43510	SPRING	1				0.02	0.044
190	04013-50100	WASHER PLAIN	1				0	0
200	02116-50100	NUT	2				0.004	0.0088
210	66204-43490	PLATE FRICTION	2				0.004	0.0088
220	66204-43530	DAMPER	1				0.3	0.66
230	02112-50080	NUT	2				0.003	0.0066
240	04012-50080	WASHER PLAIN	1				0.001	0.0022
250	05122-50830	PIN JOINT	2				0.014	0.0308
260	04012-50080	WASHER PLAIN	2				0.001	0.0022
270	05511-50215	PIN SPLIT	2				0.001	0.0022
280	66204-43520	WASHER LOCK	1				0.03	0.066
290	01023-50610	BOLT	1				0.005	0.011
300	04013-50060	WASHER PLAIN	1				0	0
310	66204-43600	ASSY BOLT DAMPER	1				0.035	0.077
320	66204-43610	BOLT FULCRUM	1				0.03	0.066
330	66204-43540	BUSH RUBBER	1				0.002	0.0044
340	66204-43620	COLLAR	1				0.01	0.022

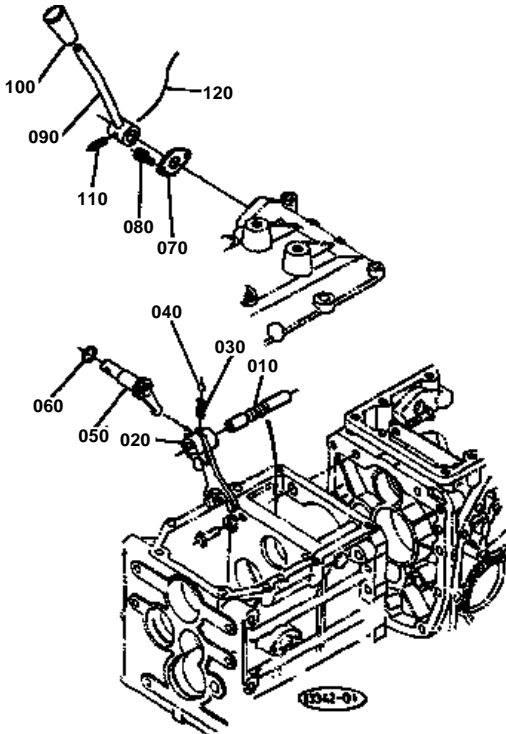



↔ Interchangeable; ≠ not interchangeable; ← new for old; → old for new

REF.No	Part No.	Description	Q'ty	S.No.	I/C	REMARKS	Weight (kgf)	Weight (lb)
010	66204-18410	SHAFT HI-LO FORK	1				0.095	0.209
020	66204-18420	FORK HI-LO SHIFT	1				0.165	0.363
030	62061-18260	SPRING STOPPER	1				0.002	0.0044
040	07715-01605	BALL	1				0.003	0.0066
050	66591-18170	ARM HI-LO SHIFT	1				0.106	0.2332
060	04811-00160	O RING	1				0.001	0.0022
070	66591-18180	RETAINER FORK ROD	1				0.012	0.0264
080	01202-50614	BOLT	2				0.006	0.0132
090	66204-42510	LEVER HI-LO SHIFT	1				0.2	0.44
100	54201-23270	GRIP	1				0.02	0.044
110	05411-00630	PIN SPRING	1				0.004	0.0088
120	99999-99999	WIRE	1			OBTAINED LOCALLY	0	0

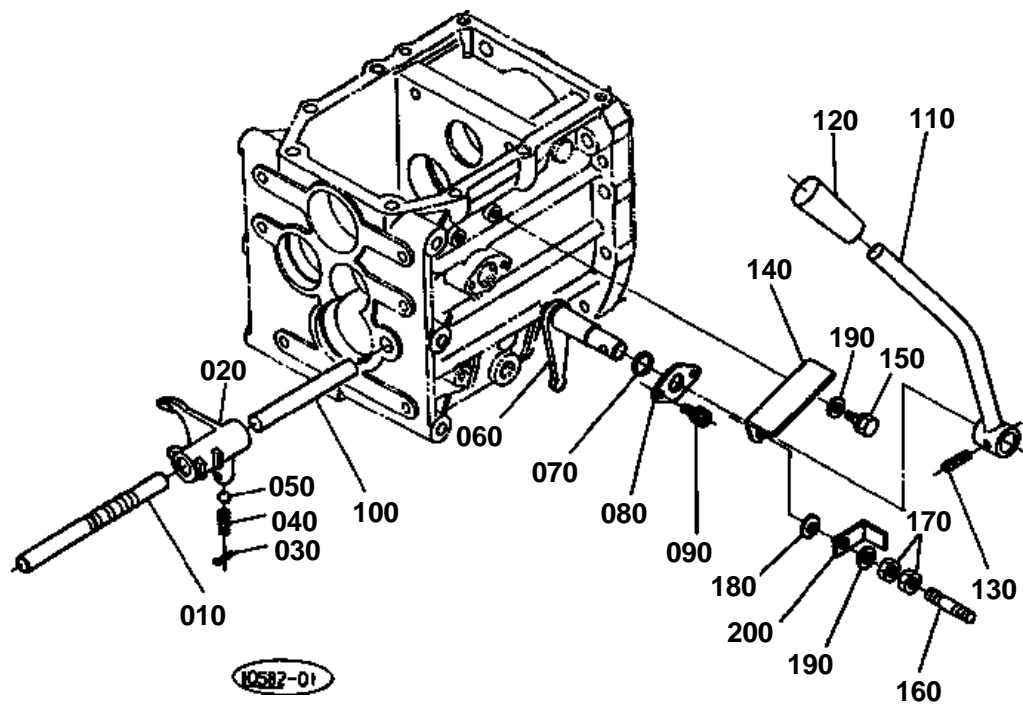



↔ Interchangeable; ≠ not interchangeable; ← new for old; → old for new

REF.No	Part No.	Description	Q'ty	S.No.	I/C	REMARKS	Weight (kgf)	Weight (lb)
010	66204-18610	SHAFT FORK	1				0.21	0.462
020	66591-18216	FORK SHIFT	1				0.19	0.418
030	05511-50322	PIN SPLIT	1				0.002	0.0044
040	62061-18260	SPRING STOPPER	1				0.002	0.0044
050	07715-01605	BALL	1				0.003	0.0066
060	66591-18220	ARM	1				0.12	0.264
070	04811-00160	O RING	1				0.001	0.0022
080	66591-18180	RETAINER FORK ROD	1				0.012	0.0264
090	01202-50614	BOLT	2				0.006	0.0132
100	66611-19310	RETAINER ROD	1				0.129	0.2838
110	66611-42710	LEVER SHIFT	1				0.237	0.5214
120	54201-23270	GRIP	1				0.02	0.044
130	05411-00630	PIN SPRING	1				0.004	0.0088
140	66204-42170	GUIDE SPEED CHANGE	1				0.04	0.088
150	01202-50814	BOLT	1				0.011	0.0242
160	01513-50825	STUD	1				0	0
170	02114-50080	NUT	2				0.005	0.011
180	66116-51530	SPRING PLATE	1				0.004	0.0088
190	04013-50080	WASHER PLAIN	2				0	0
200	66204-42180	STOPPER	1				0.03	0.066

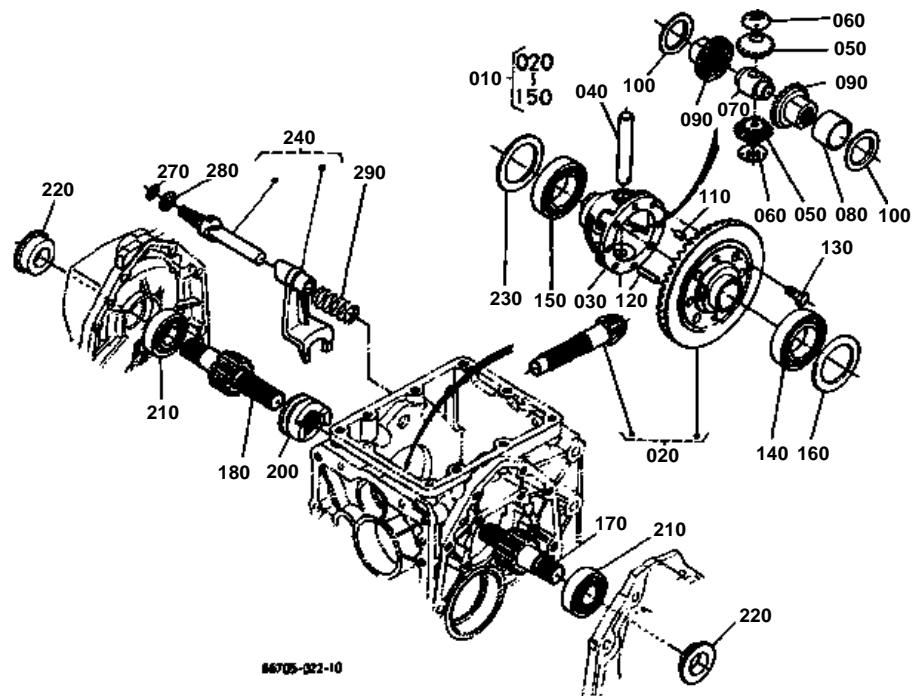



↔ Interchangeable; ≠ not interchangeable; ← new for old; → old for new

REF.No	Part No.	Description	Q'ty	S.No.	I/C	REMARKS	Weight (kgf)	Weight (lb)
010	66204-81303	ASSY DIFF REAR	1				4.1	9.02
020	66204-82714	ASSY GEAR BEVEL	1			6-37T	1.5	3.3
030	67311-14973	CASE DIFFERENTIAL	1				0.7	1.54
040	67711-14912	SHAFT DIFF.PINION	1				0.14	0.308
050	67711-14920	PINION DIFF.	2			12T	0.11	0.242
060	67311-14980	COLLAR PINION THRUST	2				0.002	0.0044
070	66591-14860	COLLAR THRUST	1				0.102	0.2244
080	66611-14950	BUSH	1				0.032	0.0704
090	67211-15150	GEAR DIFF.SIDE	2			14T	0.158	0.3476
100	67211-15160	SHIM	1			1.0MM	0.01	0.022
100	67211-15170	SHIM	1			0.8MM	0.008	0.0176
100	67211-15180	SHIM	1			1.2MM	0.01	0.022
110	66591-14792	PIN KNOCK	1				0.003	0.0066
120	66591-14783	PIN STRAIGHT	1				0.01	0.022
130	67810-56680	BOLT UBS	6				0.013	0.0286
140	08101-06009	BEARING BALL	1				0.22	0.484
150	08101-06010	BEARING BALL	1				0.262	0.5764
160	66591-14980	SHIM DIFF.SIDE	1			0.5MM	0.005	0.011
160	66591-14990	SHIM DIFF.SIDE	1			0.2MM	0.002	0.0044
170	66611-15110	SHAFT DIFF.GEAR LH	1				0.58	1.276
180	66611-15120	SHAFT DIFF.GEAR RH	1				0.68	1.496
190	99999-99999	BLANK	0				0	0
200	66611-15130	CLUTCH DIFF.LOCK	1				0.2	0.44
210	08101-06305	BEARING BALL	2				0.23	0.506
220	66611-14940	SEAL OIL	2				0.02	0.044
230	66611-15140	SHIM DIFF.SIDE	1			0.5MM	0.006	0.0132
230	66611-15150	SHIM DIFF.SIDE	1			0.2MM	0.002	0.0044
240	66611-19100	ASSY FORK DIFF.LOCK	1				0.42	0.924
250	99999-99999	BLANK	0				0	0
260	99999-99999	BLANK	0				0	0
270	04811-10120	O RING	1				0.001	0.0022
280	66591-18340	SHIM	2				0.001	0.0022
290	66591-18320	SPRING	1				0.02	0.044

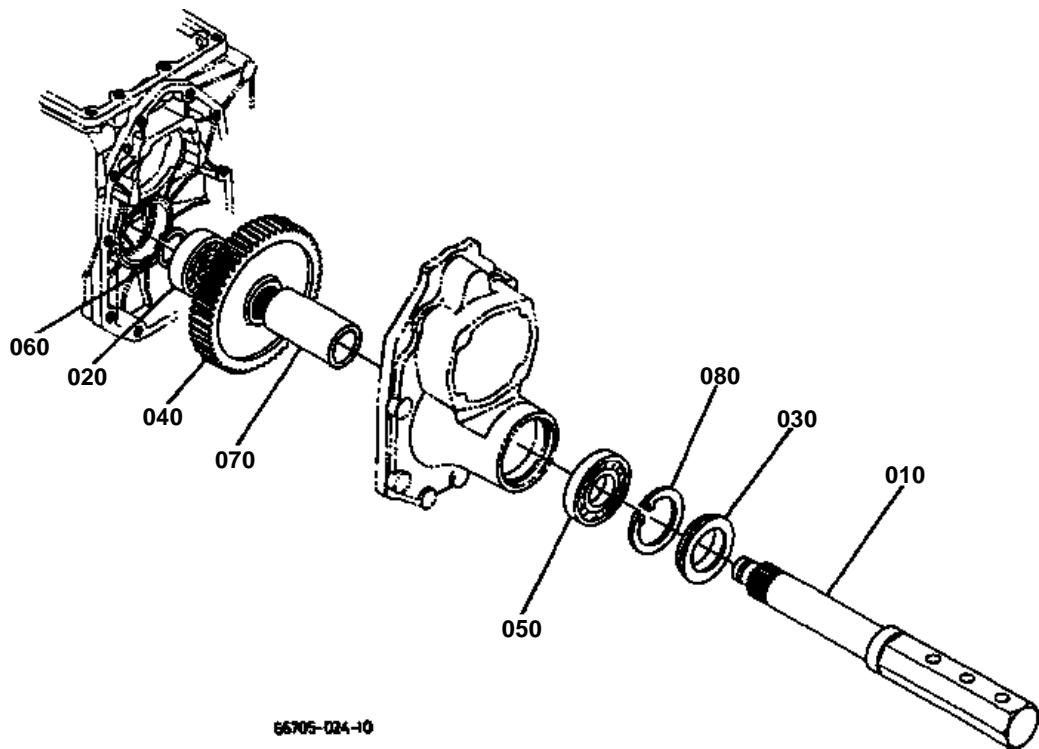



↔ Interchangeable; ≠ not interchangeable; ← new for old; → old for new

REF.No	Part No.	Description	Q'ty	S.No.	I/C	REMARKS	Weight (kgf)	Weight (lb)
010	66611-17114	AXLE REAR	2				4.64	10.208
020	08101-06306	BEARING BALL	2				0.335	0.737
030	66611-17120	SEAL OIL	2				0.09	0.198
040	66611-17130	GEAR	2			55T	2.4	5.28
050	08101-06208	BEARING BALL	2				0.355	0.781
060	04612-00300	CIR CLIP EXTERNAL	2				0.003	0.0066
070	66611-17143	COLLAR	2				0.515	1.133
080	04611-00800	CIR CLIP INTERNAL	2				0.02	0.044

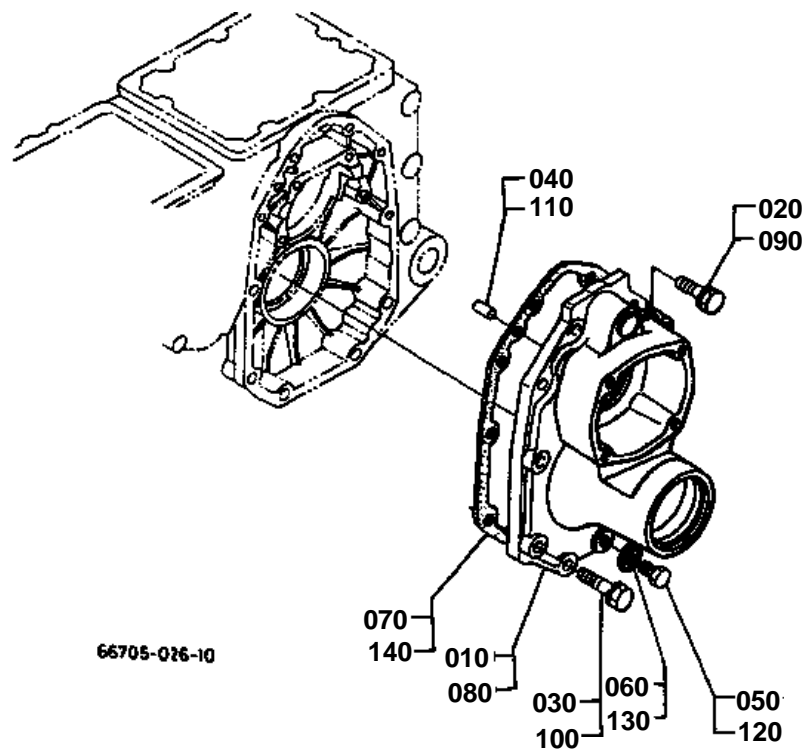



↔ Interchangeable; ≠ not interchangeable; ← new for old; → old for new

REF.No	Part No.	Description	Q'ty	S.No.	I/C	REMARKS	Weight (kgf)	Weight (lb)
010	66611-12614	CASE AXLE LH	1				0	0
020	01123-51035	BOLT	4				0.025	0.055
030	01123-51250	BOLT	6				0.055	0.121
040	05012-00816	PIN STRAIGHT	2				0.007	0.0154
050	06331-35012	PLUG	1				0.022	0.0484
060	04717-01200	WASHER WITH RUBBER	1				0.002	0.0044
070	66591-11240	GASKET	1				0	0
080	66611-12714	CASE AXLE RH	1				0	0
090	01123-51035	BOLT	4				0.025	0.055
100	01123-51250	BOLT	6				0.055	0.121
110	05012-00816	PIN STRAIGHT	2				0.007	0.0154
120	06331-35012	PLUG	1				0.022	0.0484
130	04717-01200	WASHER WITH RUBBER	1				0.002	0.0044
140	66591-11240	GASKET	1				0	0

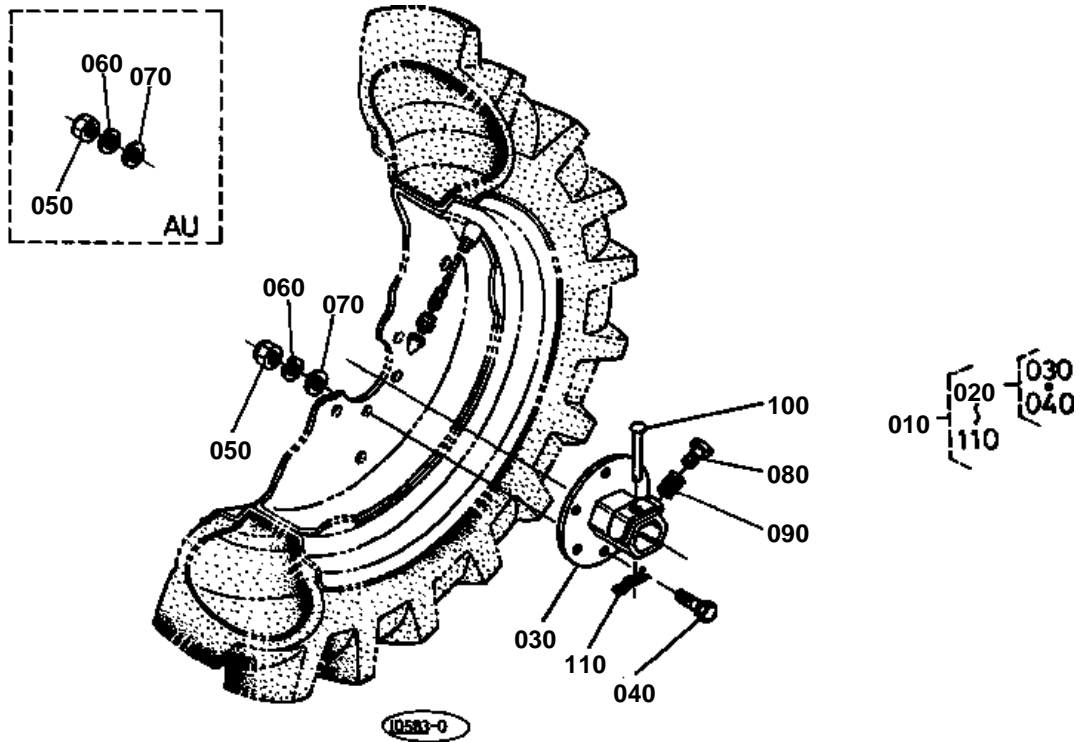



↔ Interchangeable; ≠ not interchangeable; ← new for old; → old for new

REF.No	Part No.	Description	Q'ty	S.No.	I/C	REMARKS	Weight (kgf)	Weight (lb)
010	66704-17220	ASSY HUB WHEEL	2			[A] [CA]	0	0
010	67011-17300	ASSY HUB WHEEL	2			[AU]	0	0
020	66722-17300	ASSY HUB BOLT	2				0	0
030	66722-17150	HUB WHEEL	2				2.8	6.16
040	66704-17313	BOLT	12				0.049	0.1078
050	35340-11390	NUT	12			[A] [CA]	0.03	0.066
050	02074-50140	NUT	12			[AU]	0.021	0.0462
060	04512-50140	WASHER SPRING	12				0	0
070	04013-50140	WASHER PLAIN	12				0	0
080	63733-17250	SCREW	2				0.08	0.176
090	63512-17230	SPRING SET BOLT	2				0.014	0.0308
100	66621-17160	PIN AXLE	2				0.05	0.11
110	62131-17290	PIN	2				0.004	0.0088

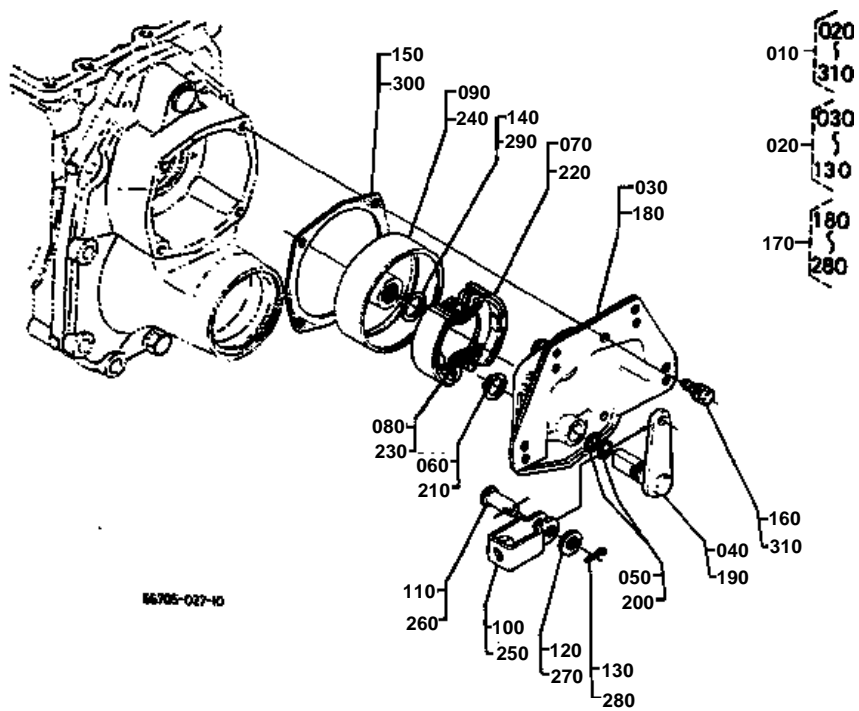



↔ Interchangeable; ≠ not interchangeable; ← new for old; → old for new

REF.No	Part No.	Description	Q'ty	S.No.	I/C	REMARKS	Weight (kgf)	Weight (lb)
010	66905-22100	ASSY BRAKE NA	1				5.13	11.286
020	66905-22302	ASSY BRAKE LH NA	1				2.58	5.676
030	66611-22312	COVER BRAKE LH	1				1.04	2.288
040	66591-22330	CAM BRAKE LH	1				0.204	0.4488
050	04811-05170	O RING	2				0.001	0.0022
060	04612-00200	CIR CLIP EXTERNAL	1				0.001	0.0022
070	66611-88800	SHOE BRAKE	2	<=63884			0	0
070	66905-22390	KIT SHOE BRAKE	1	>=63885	↔	SET	0.35	0.77
080	66591-22350	SPRING RETURN	2				0.003	0.0066
090	66611-22360	DRUM BRAKE	1				0	0
100	63753-42350	U JOINT	1				0.038	0.0836
110	05122-50820	PIN JOINT	1				0.009	0.0198
120	04012-50080	WASHER PLAIN	1				0.001	0.0022
130	05511-50215	PIN SPLIT	1				0.001	0.0022
140	04612-00220	CIR CLIP EXTERNAL	1				0.001	0.0022
150	66591-22410	GASKET BRAKE	1				0	0
160	01123-50822	BOLT	4				0.012	0.0264
170	66905-22402	ASSY BRAKE RH	1				2.58	5.676
180	66611-22412	COVER BRAKE RH	1				1.05	2.31
190	66591-22370	CAM BRAKE RH	1				0.204	0.4488
200	04811-05170	O RING	2				0.001	0.0022
210	04612-00200	CIR CLIP EXTERNAL	1				0.001	0.0022
220	66611-88800	SHOE BRAKE	2	<=63884			0	0
220	66905-22390	KIT SHOE BRAKE	1	>=63885	↔	SET	0.35	0.77
230	66591-22350	SPRING RETURN	2				0.003	0.0066
240	66611-22360	DRUM BRAKE	1				0	0
250	63753-42350	U JOINT	1				0.038	0.0836
260	05122-50820	PIN JOINT	1				0.009	0.0198
270	04012-50080	WASHER PLAIN	1				0.001	0.0022
280	05511-50215	PIN SPLIT	1				0.001	0.0022
290	04612-00220	CIR CLIP EXTERNAL	1				0.001	0.0022
300	66591-22410	GASKET BRAKE	1				0	0
310	01123-50822	BOLT	4				0.012	0.0264

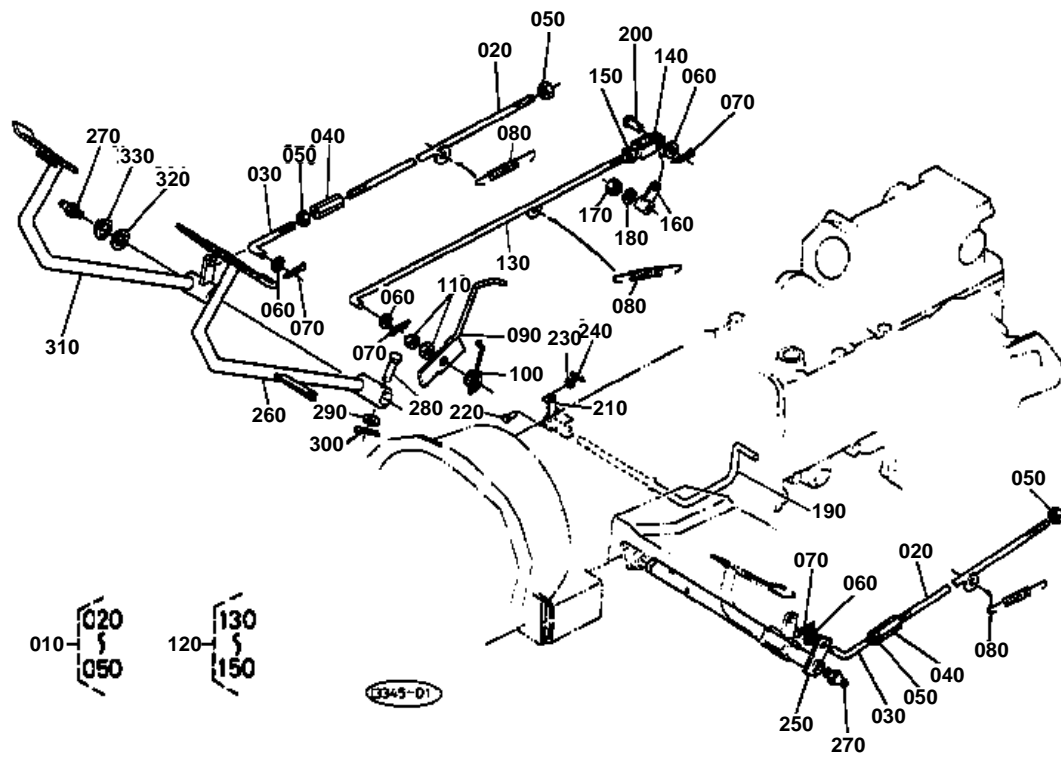



↔ Interchangeable; ≠ not interchangeable; ← new for old; → old for new

REF.No	Part No.	Description	Q'ty	S.No.	I/C	REMARKS	Weight (kgf)	Weight (lb)
010	66204-42800	ASSY ROD BRAKE	2				0.31	0.682
020	66204-42810	ROD BRAKE	2	<=63788			0	0
020	66204-42813	ROD BRAKE	2	>=63789	←		0.23	0.506
030	66621-43250	ROD BRAKE FRONT	2				0.024	0.0528
040	66591-42410	TURNBUCKLE	2				0.046	0.1012
050	02112-50080	NUT	4				0.003	0.0066
060	04012-50080	WASHER PLAIN	4				0.001	0.0022
070	05511-50318	PIN SPLIT	4				0.001	0.0022
080	66591-43190	SPRING BRAKE RETURN	3				0.044	0.0968
090	66204-42850	LEVER BRAKE LOCK	1				0.12	0.264
100	66204-42840	SPRING BRAKE LOCK	1				0.006	0.0132
110	02172-50120	NUT	2				0.01	0.022
120	66204-42820	ASSY ROD DIFF.LOCK	1				0.312	0.6864
130	66204-42860	ROD DIFF.LOCK	1				0.29	0.638
140	63753-42350	U JOINT	1				0.038	0.0836
150	02112-50080	NUT	1				0.003	0.0066
160	66591-43170	LEVER DIFF.LOCK	1				0.041	0.0902
170	02118-50100	NUT	1				0.005	0.011
180	04512-50100	WASHER SPRING	1				0	0
190	66204-42870	SHAFT DIFF LOCK	1				0.715	1.573
200	05122-50820	PIN JOINT	1				0.009	0.0198
210	66204-42880	LEVER DIFF.LOCK	1				0.12	0.264
220	66611-14120	PIN JOINT	1				0	0
230	04012-50050	WASHER PLAIN	1				0.001	0.0022
240	05511-50215	PIN SPLIT	1				0.001	0.0022
250	66204-42910	SHAFT BRAKE PEDAL	1				1.6	3.52
260	66213-42920	PEDAL BRAKE LH	1				1.65	3.63
270	06613-10010	NIPPLE GREASE	2				0.006	0.0132
280	05112-50840	PIN JOINT	1				0.017	0.0374
290	04012-50080	WASHER PLAIN	1				0.001	0.0022
300	05511-50215	PIN SPLIT	1				0.001	0.0022
310	66213-42930	PEDAL BRAKE RH	1				1.5	3.3
320	66591-43233	COLLAR	1				0.004	0.0088
330	04612-00240	CIR CLIP EXTERNAL	1				0.002	0.0044

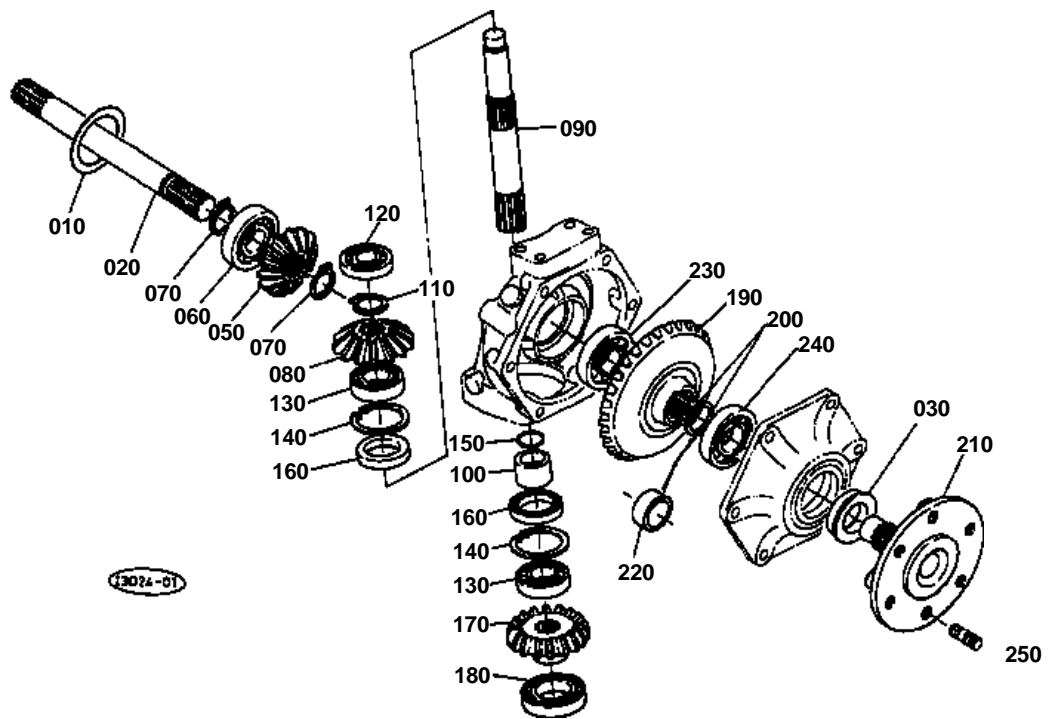



↔ Interchangeable; ≠ not interchangeable; ← new for old; → old for new

REF.No	Part No.	Description	Q'ty	S.No.	I/C	REMARKS	Weight (kgf)	Weight (lb)
010	66591-14980	SHIM DIFF.SIDE	2			0.5MM	0.005	0.011
010	66591-14990	SHIM DIFF.SIDE	2			0.2MM	0.002	0.0044
010	67121-56630	SHIM DIFF.SIDE	2			0.3MM	0.005	0.011
020	67121-56640	SHAFT	2				0.98	2.156
030	63733-17150	SEAL OIL	2				0.04	0.088
040	99999-99999	BLANK	0				0	0
050	67121-56650	GEAR BEVEL	2			13T	0.38	0.836
060	08101-06305	BEARING BALL	2				0.23	0.506
070	04612-00250	CIR CLIP EXTERNAL	4				0.002	0.0044
080	67121-56710	GEAR BEVEL	2			14T	0.35	0.77
090	67121-56720	SHAFT BEVEL GEAR	2				0.73	1.606
100	67121-56730	COLLAR SUPPORT	2				0.075	0.165
110	04612-00250	CIR CLIP EXTERNAL	2				0.002	0.0044
120	08101-06303	BEARING BALL	2				0.112	0.2464
130	67121-56760	BEARING BALL	4	<=65015			0	0
130	67121-56770	BEARING BALL	4	>=65016	←		0.127	0.2794
140	04611-00520	CIR CLIP INTERNAL	4				0.009	0.0198
150	04811-10250	O RING	2				0.001	0.0022
160	67121-56740	SEAL OIL	4				0.016	0.0352
170	67221-56750	GEAR BEVEL	2			16T	0.58	1.276
180	08101-06007	BEARING BALL	2				0.16	0.352
190	67121-56810	GEAR BEVEL	2			31T	2	4.4
200	67156-56820	COLLAR SET	4				0.004	0.0088
210	67401-56830	HUB FRONT WHEEL	2				1.66	3.652
220	66204-56840	COLLAR	2				0.02	0.044
230	08101-06305	BEARING BALL	2				0.23	0.506
240	08101-06206	BEARING BALL	2				0.196	0.4312
250	66758-56970	BOLT STUD	12				0.03	0.066
260	04013-50120	WASHER PLAIN	12			NOT SHOWN IN FIG.	0	0
270	04512-50120	WASHER SPRING	12			NOT SHOWN IN FIG.	0.003	0.0066
280	02174-50120	NUT	12			NOT SHOWN IN FIG.	0.01	0.022

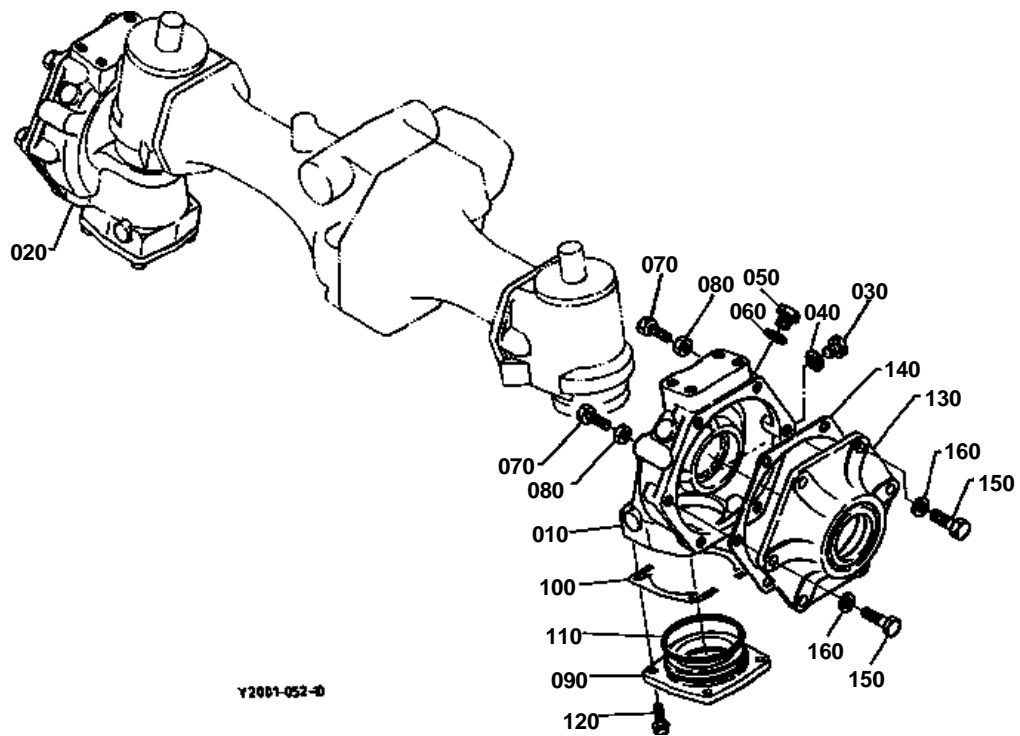

Y2001-052-B



↔ Interchangeable; ≠ not interchangeable; ← new for old; → old for new

REF.No	Part No.	Description	Q'ty	S.No.	I/C	REMARKS	Weight (kgf)	Weight (lb)
010	67121-56310	CASE FRONT AXLE LH	1				4.5	9.9
020	67121-56320	CASE FRONT AXLE RH	1				0	0
030	06331-35010	PLUG	2				0.012	0.0264
040	04717-01000	WASHER WITH RUBBER	2				0.001	0.0022
050	06331-35012	PLUG	2				0.022	0.0484
060	04717-01200	WASHER WITH RUBBER	2				0.002	0.0044
070	66591-56440	BOLT ADJUSTING	2				0.02	0.044
080	02112-50100	NUT	2				0.004	0.0088
090	67121-56330	COVER BEVEL	2				0.64	1.408
100	67121-56340	SHIM	4			0.5MM	0.004	0.0088
100	67121-56360	SHIM	4			0.3MM	0.001	0.0022
100	67121-56360	SHIM	4			0.2MM	0.001	0.0022
110	04811-50750	O RING	2				0.002	0.0044
120	01123-50825	BOLT	8				0.013	0.0286
130	66204-56370	COVER FRONT AXLE	2				2	4.4
140	67121-56380	GASKET	2				0	0
150	01153-51028	BOLT	12				0.02	0.044
160	04512-50100	WASHER SPRING	12				0	0

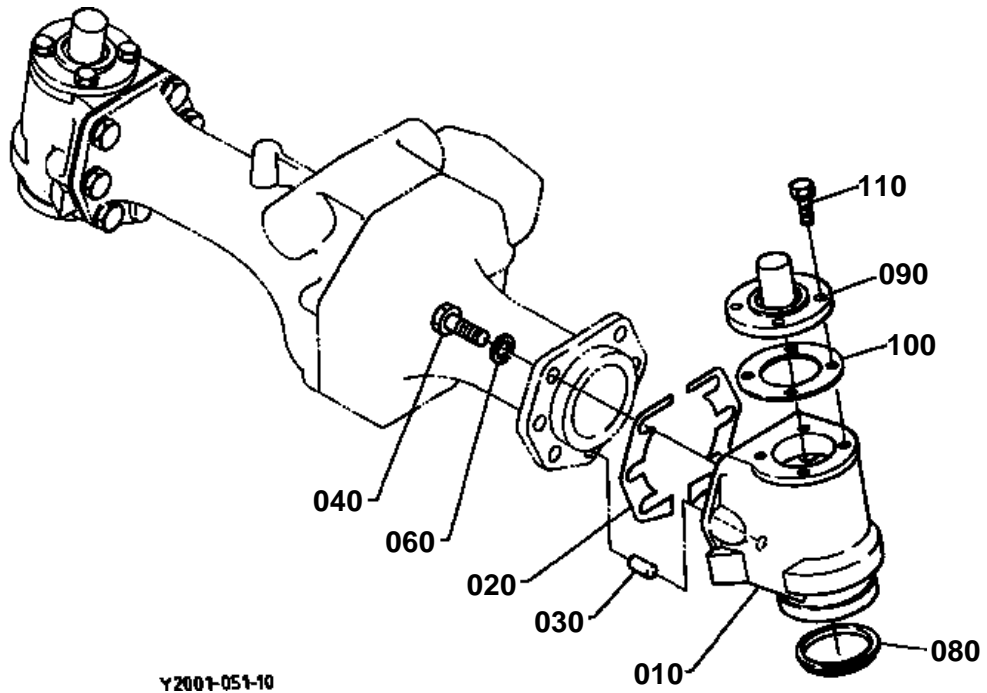



↔ Interchangeable; ≠ not interchangeable; ← new for old; → old for new

REF.No	Part No.	Description	Q'ty	S.No.	I/C	REMARKS	Weight (kgf)	Weight (lb)
010	67121-56210	CASE BEVEL GEAR	2				2.6	5.72
020	67121-56240	SHIM	4			0.2MM	0.003	0.0066
020	67121-56230	SHIM	4			0.3MM	0.004	0.0088
030	05012-01020	PIN STRAIGHT	2				0.02	0.044
040	01153-51228	BOLT	12				0.034	0.0748
050	99999-99999	BLANK	0				0	0
060	04512-50120	WASHER SPRING	12				0.003	0.0066
070	99999-99999	BLANK	0				0	0
080	67121-56250	SEAL DUST	2				0.001	0.0022
090	67121-56263	SUPPORT KNUCKLE ARM	2				0.4	0.88
100	67121-56270	GASKET	2				0	0
110	01123-50822	BOLT	8				0.012	0.0264

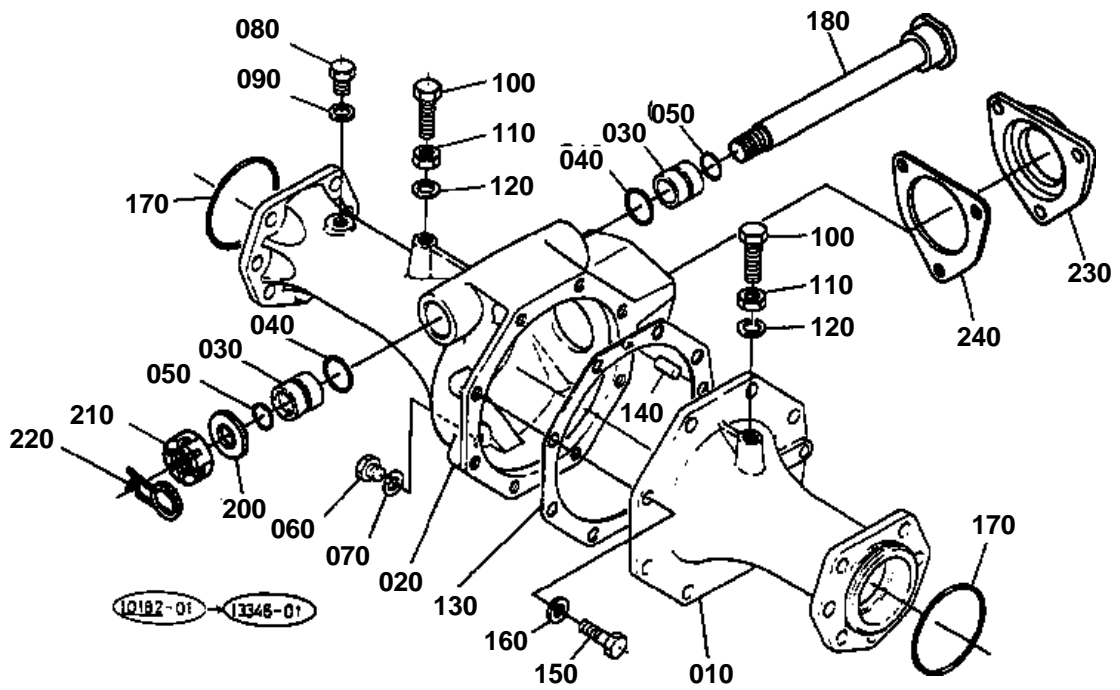



FRONT AXLE ARM TRACTOR S.No.:B7100HST-D >=60164 B7100HST-E >=20025

↔ Interchangeable; ≠ not interchangeable; ← new for old; → old for new

REF.No	Part No.	Description	Q'ty	S.No.	I/C	REMARKS	Weight (kgf)	Weight (lb)
010	67121-56110	ARM FRONT AXLE LH	1				5.6	12.32
020	66204-56120	ARM KNUCKLE RH	1				9	19.8
030	66591-56120	BUSH	2				0.074	0.1628
040	04811-50250	O RING	2				0.001	0.0022
050	04811-00200	O RING	2				0.001	0.0022
060	06331-35010	PLUG	1				0.012	0.0264
070	04717-01000	WASHER WITH RUBBER	1				0.001	0.0022
080	06331-35012	PLUG	1				0.022	0.0484
090	04717-01200	WASHER WITH RUBBER	1				0.002	0.0044
100	67401-56280	BOLT	2				0.035	0.077
110	02112-50120	NUT	2				0.007	0.0154
120	04512-50120	WASHER SPRING	2				0.003	0.0066
130	67121-56130	GASKET	1				0	0
140	05012-01020	PIN STRAIGHT	1				0.02	0.044
150	01153-51028	BOLT	8				0.02	0.044
160	04512-50100	WASHER SPRING	8				0	0
170	04811-10750	O RING	2				0.001	0.0022
180	66802-56110	PIN CENTER	1				0.58	1.276
190	99999-99999	BLANK	0				0	0
200	04011-50180	WASHER PLAIN	1				0.012	0.0264
210	02372-50180	NUT	1				0.019	0.0418
220	66611-57150	SPRING SET	1				0.02	0.044
230	66591-56183	COVER	1				0.415	0.913
240	66591-56172	GASKET	1				0	0

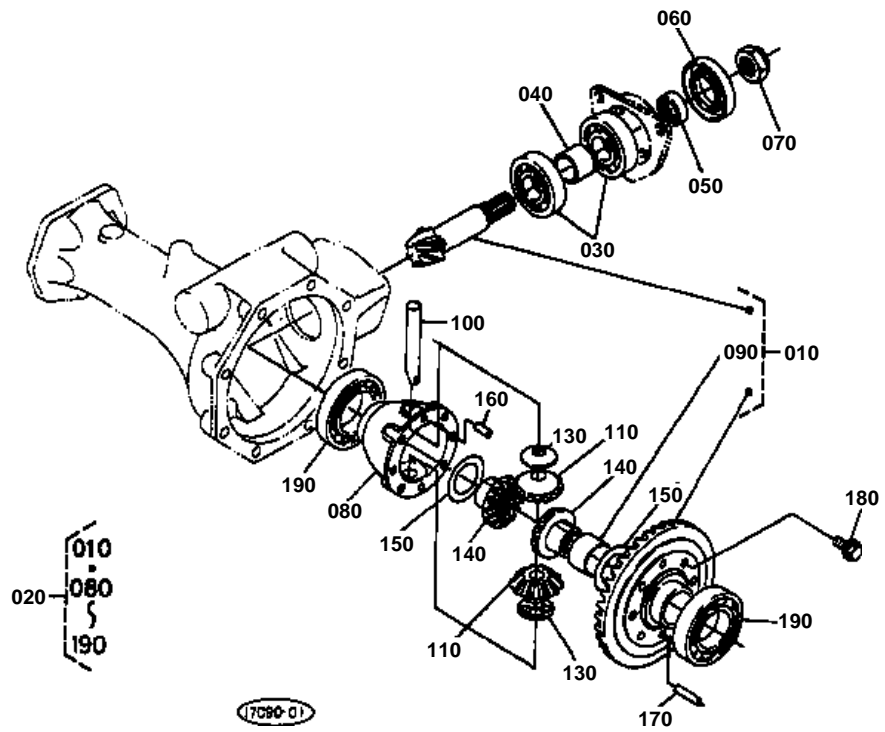



↔ Interchangeable; ≠ not interchangeable; ← new for old; → old for new

REF.No	Part No.	Description	Q'ty	S.No.	I/C	REMARKS	Weight (kgf)	Weight (lb)
010	67121-99120	ASSY GEAR BEVEL	1			6-37T	2	4.4
020	67721-82900	ASSY DIFF. FRONT	1	≤64183			0	0
020	67221-82903	ASSY DIFF. FRONT	1	≥64184	↔		4.1	9.02
030	08101-06305	BEARING BALL	2				0.23	0.506
040	66591-56463	COLLAR	1				0.05	0.11
050	66591-56420	BUSH	1				0.021	0.0462
060	66591-56430	SEAL OIL	1				0.019	0.0418
070	35260-23252	NUT	1				0.04	0.088
080	67321-56612	CASE FRONT DIFF.	1				0.61	1.342
090	66611-14950	BUSH	1				0.032	0.0704
100	67711-14912	SHAFT DIFF.PINION	1				0.14	0.308
110	67711-14920	PINION DIFF.	2			12T	0.11	0.242
120	99999-99999	BLANK	0				0	0
130	67311-14980	COLLAR PINION THRUST	2				0.002	0.0044
140	67211-15150	GEAR DIFF.SIDE	2				0.158	0.3476
150	67211-15160	SHIM	2			1.0MM	0.01	0.022
150	67211-15170	SHIM	2			0.8MM	0.008	0.0176
150	67211-15180	SHIM	2			1.2MM	0.01	0.022
160	66591-14792	PIN KNOCK	1				0.003	0.0066
170	66591-14783	PIN STRAIGHT	1				0.01	0.022
180	67810-56680	BOLT UBS	6				0.013	0.0286
190	08101-06009	BEARING BALL	2				0.22	0.484

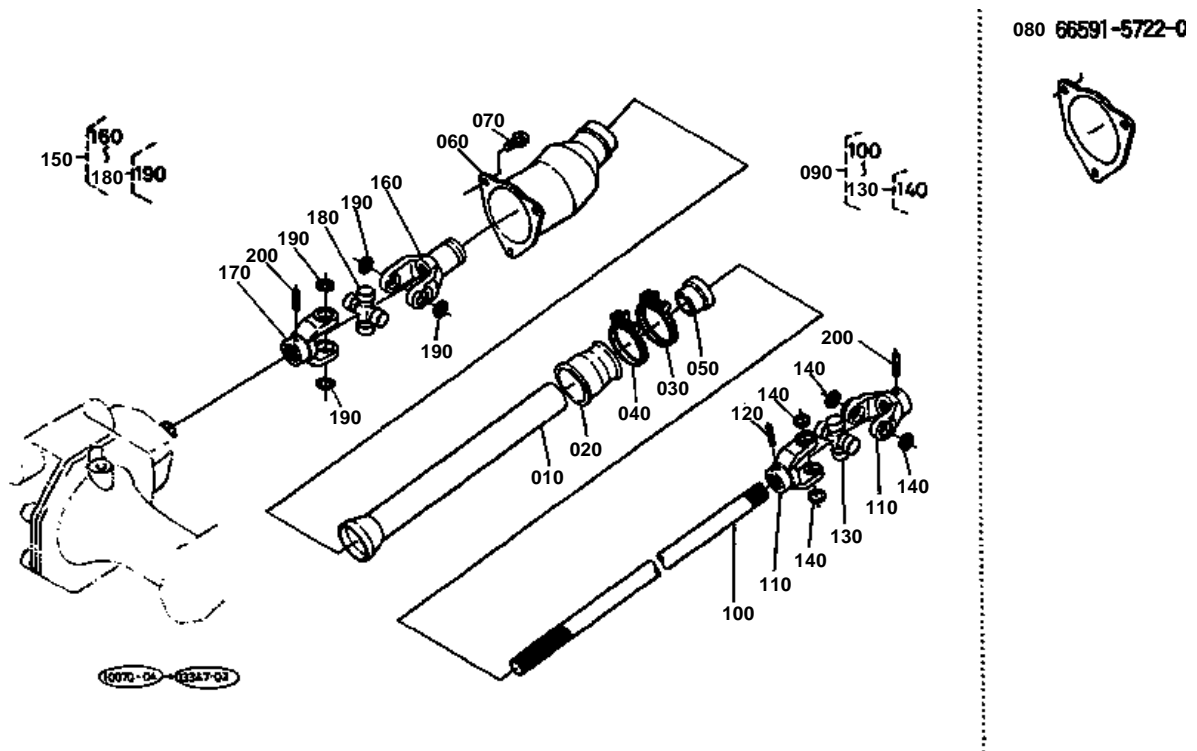



↔ Interchangeable; ≠ not interchangeable; ← new for old; → old for new

REF.No	Part No.	Description	Q'ty	S.No.	I/C	REMARKS	Weight (kgf)	Weight (lb)
010	66591-57164	PIPE	1				0.429	0.9438
020	66591-57170	PIPE	1				0.046	0.1012
030	15108-72870	BAND	1				0.027	0.0594
040	15221-11720	CLAMP HOSE	1				0.03	0.066
050	67121-57150	SEAL OIL	1				0.018	0.0396
060	67221-57110	CASE JOINT	1				0.56	1.232
070	01123-50835	BOLT	3				0.02	0.044
080	66591-57220	GASKET	1	←=63884			0	0
090	66711-57200	ASSY SHAFT DRIVE	1				2.045	4.499
100	66711-57210	SHAFT DRIVE	1				1.32	2.904
110	66591-56310	JOINT	2				0.25	0.55
120	05411-00628	PIN SPRING	1				0.004	0.0088
130	66591-56320	ASSY JOINT CROSS	1				0.185	0.407
140	04611-00200	CIR CLIP INTERNAL	4				0.001	0.0022
150	67121-57250	ASSY JOINT FRONT	1				0.77	1.694
160	66591-56340	JOINT	1				0.338	0.7436
170	66591-56310	JOINT	1				0.25	0.55
180	66591-56320	ASSY JOINT CROSS	1				0.185	0.407
190	04611-00200	CIR CLIP INTERNAL	4				0.001	0.0022
200	05411-00628	PIN SPRING	2				0.004	0.0088

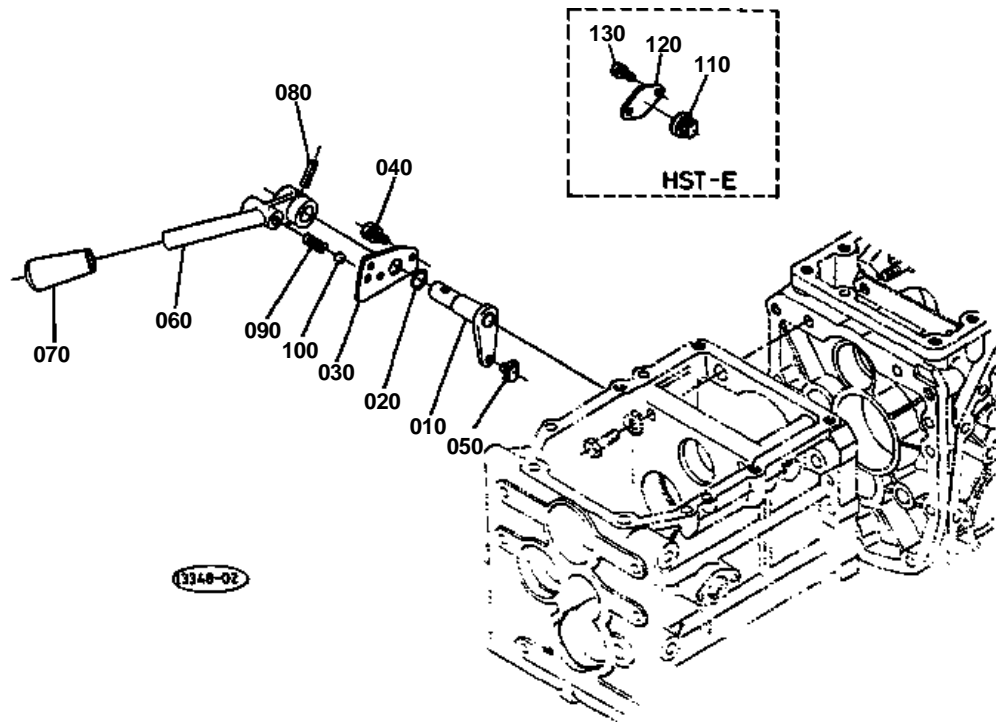



↔ Interchangeable; ≠ not interchangeable; ← new for old; → old for new

REF.No	Part No.	Description	Q'ty	S.No.	I/C	REMARKS	Weight (kgf)	Weight (lb)
010	66611-19210	LEVER FORK	1				0.12	0.264
020	04811-00160	O RING	1				0.001	0.0022
030	66204-19220	RETAINER FORK ROD	1				0.03	0.066
040	01202-50614	BOLT	2				0.006	0.0132
050	66611-19230	SHIFTER	1				0.012	0.0264
060	66204-42610	LEVER FRONT DRIVE	1				0.16	0.352
070	54201-23270	GRIP	1				0.02	0.044
080	05411-00630	PIN SPRING	1				0.004	0.0088
090	62061-18260	SPRING STOPPER	1				0.002	0.0044
100	07715-01605	BALL	1				0.003	0.0066

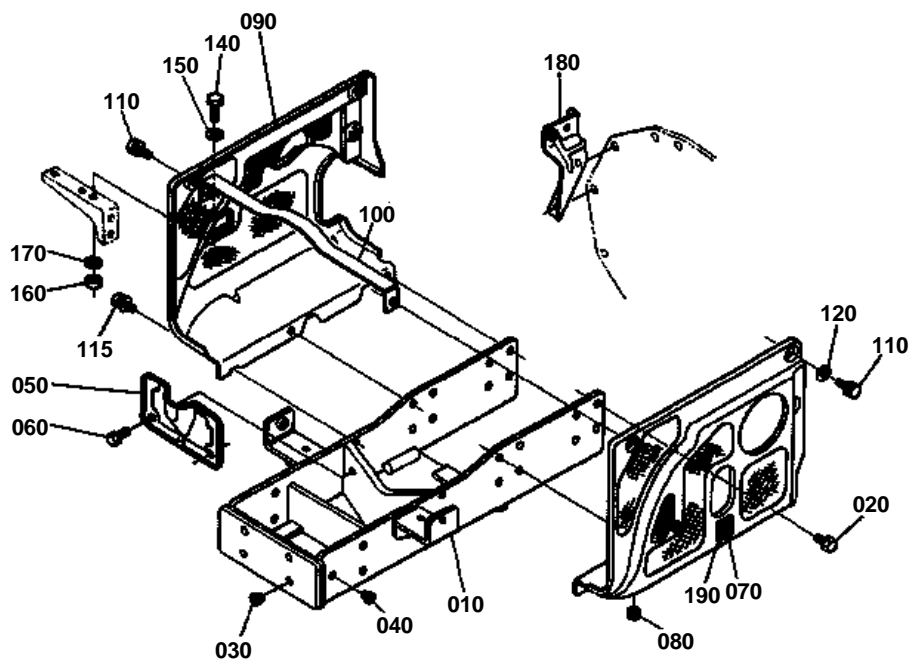

66705-005-11

110 01202-50614
130 04015-50060





↔ Interchangeable; ≠ not interchangeable; ← new for old; → old for new

REF.No	Part No.	Description	Q'ty	S.No.	I/C	REMARKS	Weight (kgf)	Weight (lb)
010	66704-51210	SUPPORT FRONT WHEEL	1				17	37.4
020	01133-51025	BOLT	16				0.023	0.0506
030	67211-51120	PLUG	8				0.001	0.0022
040	67211-11140	PLUG	6				0.001	0.0022
050	66704-51280	COVER FRONT	1				0.11	0.242
060	01123-50825	BOLT	2				0.013	0.0286
070	66728-51370	COVER SIDE LH	1				0.86	1.892
080	66591-54580	RUBBER RELEASE ROD	1				0.003	0.0066
090	66213-51330	COVER SIDE RH	1				0.9	1.98
100	66711-51380	STAY SIDE COVER	1				0.215	0.473
110	01202-50614	BOLT	8	<=66628			0.006	0.0132
110	01202-50614	BOLT	6	>=66629	↔		0.006	0.0132
115	01026-50614	BOLT	2	>=66629			0.005	0.011
120	04013-50060	WASHER PLAIN	4				0	0
130	04015-50060	WASHER PLAIN	2	<=66628			0	0
140	01150-50818	BOLT	1				0	0
150	04013-50080	WASHER PLAIN	1				0	0
160	02114-50080	NUT	1				0.005	0.011
170	04512-50080	WASHER SPRING	1				0.001	0.0022
180	66711-51350	STAY FUEL	1				0.146	0.3212
190	66706-47330	LABEL OIL INSPECTION	1				0.001	0.0022

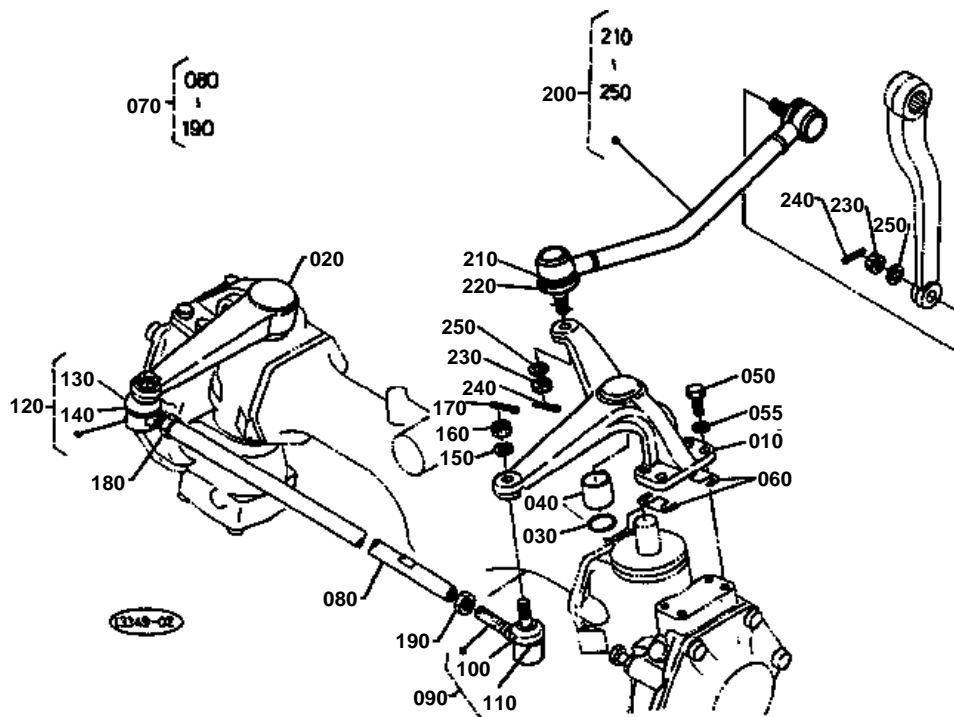



↔ Interchangeable; ≠ not interchangeable; ← new for old; → old for new

REF.No	Part No.	Description	Q'ty	S.No.	I/C	REMARKS	Weight (kgf)	Weight (lb)
010	67221-56412	ARM KNUCKLE LH	1				2.1	4.62
020	67121-56423	ARM KNUCKLE RH	1				1.57	3.454
030	04811-00250	O RING	2				0.001	0.0022
040	67121-56440	BUSH	2				0.02	0.044
050	01153-51028	BOLT	8				0.02	0.044
055	04512-50100	WASHER SPRING	8				0	0
060	67121-56450	SHIM KNUCKLE ARM	4			0.5MM	0.002	0.0044
060	67121-56460	SHIM KNUCKLE ARM	4			0.3MM	0.001	0.0022
060	67121-56470	SHIM KNUCKLE ARM	4			0.2MM	0.001	0.0022
070	67121-56500	ASSY ROD TIE	1				1.24	2.728
080	67121-56510	ROD TIE	1				0.85	1.87
090	67121-56520	END TIE ROD LH	1				0.24	0.528
100	67121-56560	COVER DUST	1				0.008	0.0176
110	67121-56570	CLIP	1				0.003	0.0066
120	67121-56530	END TIE ROD RH	1				0.23	0.506
130	67121-56560	COVER DUST	1				0.008	0.0176
140	67121-56570	CLIP	1				0.003	0.0066
150	04512-50100	WASHER SPRING	2				0	0
160	66591-56780	NUT	2				0.01	0.022
170	05511-52520	PIN SPLIT	2				0.001	0.0022
180	02172-50120	NUT	1				0.01	0.022
190	67121-56540	NUT	1				0.007	0.0154
200	66204-57100	COMP LINK DRAG	1				2.22	4.884
210	67121-56560	COVER DUST	2				0.008	0.0176
220	67121-56570	CLIP	2				0.003	0.0066
230	66591-56780	NUT	2				0.01	0.022
240	05511-52528	PIN SPLIT	2				0.001	0.0022
250	04512-50100	WASHER SPRING	2				0	0

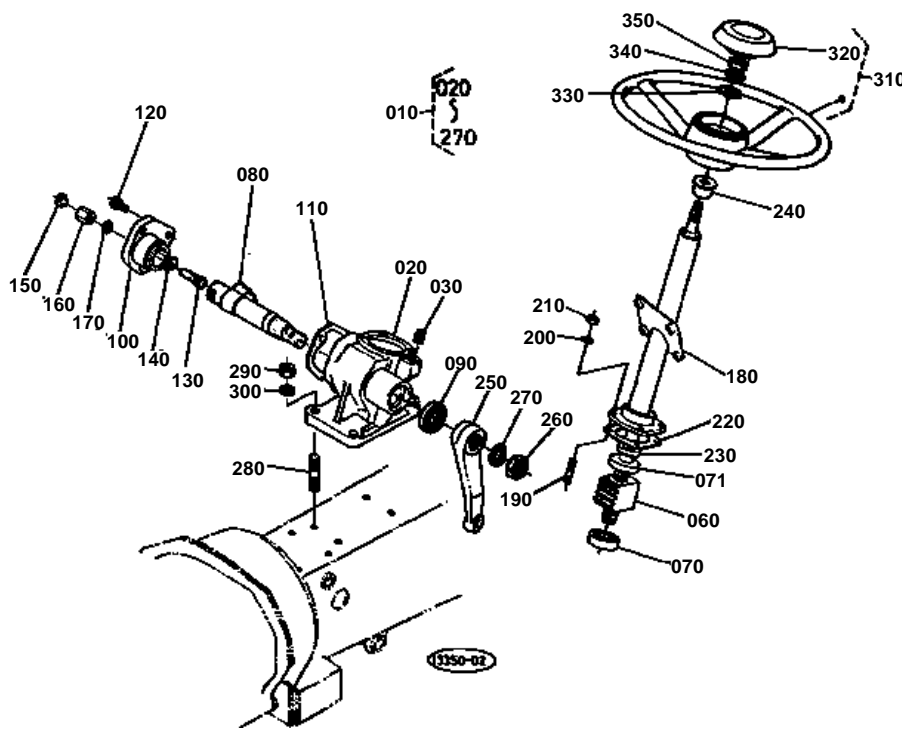

040 06331-35010
050 04717-01000

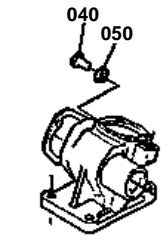

070 66811-4114-0

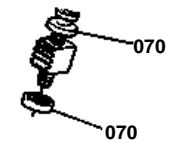



↔ Interchangeable; ≠ not interchangeable; ← new for old; → old for new

REF.No	Part No.	Description	Q'ty	S.No.	I/C	REMARKS	Weight (kgf)	Weight (lb)
010	66204-41102	ASSY STEERING	1				6.8	14.96
020	66204-41110	CASE STEERING GEAR	1	<=64183			0	0
020	66204-41113	CASE STEERING GEAR	1	>=64184	←		2.7	5.94
030	34150-16640	PLUG	1				0.015	0.033
040	06331-35010	PLUG	1	<=64183			0.012	0.0264
050	04717-01000	WASHER WITH RUBBER	1	<=64183			0.001	0.0022
060	66811-41200	COMP.NUT BALL	1				1.11	2.442
070	66811-41140	BEARING THRUST BALL	2	<=69083			0.045	0.099
070	66811-41140	BEARING THRUST BALL	1	>=69084			0.045	0.099
071	66811-91110	BEARING OUTER	1	>=69084			0.031	0.0682
080	66811-41150	SHAFT SECTOR	1				0.52	1.144
090	09500-22358	SEAL OIL	1				0.01	0.022
100	66811-41160	COVER SIDE	1				0.3	0.66
110	66811-41170	GASKET	1				0	0
120	01123-50822	BOLT	3				0.012	0.0264
130	66811-41180	SCREW ADJUSTING	1				0.013	0.0286
140	66811-41190	COLLAR ADJUSTING	1			1.515 TO 1.535MM	0.002	0.0044
140	66811-41210	COLLAR ADJUSTING	1			1.545 TO 1.565MM	0.001	0.0022
140	66811-41220	COLLAR ADJUSTING	1			1.575 TO 1.595MM	0.001	0.0022
140	66811-41230	COLLAR ADJUSTING	1			1.605 TO 1.625MM	0.001	0.0022
140	66811-41240	COLLAR ADJUSTING	1			1.635 TO 1.655MM	0.001	0.0022
150	61011-18140	PLUG RUBBER	1				0.002	0.0044
160	66811-41250	NUT	1				0.027	0.0594
170	04714-00080	GASKET	1				0.001	0.0022
180	66204-41122	POST STEERING	1				0.5	1.1
190	01513-50822	STUD	4				0.01	0.022
200	04512-50080	WASHER SPRING	4				0.001	0.0022
210	02114-50080	NUT	4				0.005	0.011
220	66811-41320	SHIM	1			0.05MM	0.001	0.0022
220	66811-41340	SHIM	1			0.08MM	0.001	0.0022
220	66811-41350	SHIM	1			0.10MM	0.001	0.0022
220	66811-41360	SHIM	1			0.20MM	0.003	0.0066
220	66811-41370	SHIM	1			0.50MM	0.007	0.0154
230	09500-16287	SEAL OIL	1				0.01	0.022
240	67211-41150	BUSH POST	1				0.016	0.0352
250	66204-41410	ARM PITMAN	1				0.4	0.88
260	02172-50160	NUT	1				0.017	0.0374
270	04512-50160	WASHER SPRING	1				0	0
280	01517-51028	STUD	4				0.022	0.0484
290	02118-50100	NUT	4				0.005	0.011
300	04512-50100	WASHER SPRING	4				0	0
310	32400-16800	ASSY WHEEL STEERING	1				1.96	4.312
320	32400-16820	PAD STEERING	1				0.05	0.11
330	04013-50120	WASHER PLAIN	1				0	0
340	04512-50120	WASHER SPRING	1				0.003	0.0066
350	02172-50120	NUT	1				0.01	0.022

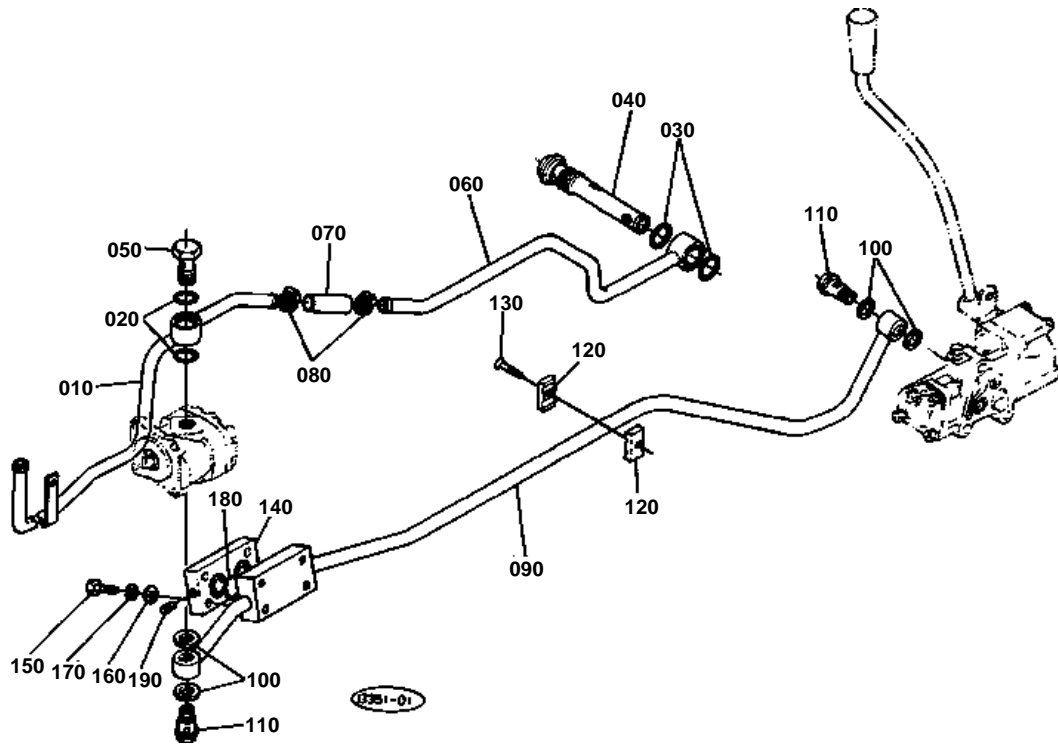



↔ Interchangeable; ≠ not interchangeable; ← new for old; → old for new

REF.No	Part No.	Description	Q'ty	S.No.	I/C	REMARKS	Weight (kgf)	Weight (lb)
010	66204-36110	PIPE SUCTION FRONT	1				0.6	1.32
020	04811-00220	O RING	2				0.001	0.0022
030	04811-10300	O RING	2				0.001	0.0022
040	66021-36390	FILTER OIL	1				0.185	0.407
050	32170-38170	BOLT HYD.PIPE JOINT	1				0.09	0.198
060	66204-36712	PIPE SUCTION REAR	1				0.66	1.452
070	66204-36720	HOSE	1				0.04	0.088
080	66204-36230	BAND PIPE	2				0.02	0.044
090	66204-36136	PIPE DELIVERY	1				1.3	2.86
100	67111-37180	GASKET	4				0.003	0.0066
110	66591-36250	JOINT	2				0.08	0.176
120	66204-36120	CLAMP PIPE	2				0.01	0.022
130	03016-50640	SCREW CSK-HD	1				0.008	0.0176
140	66604-36160	COVER	1				0.23	0.506
150	01153-50838	BOLT	4				0.017	0.0374
160	04013-50080	WASHER PLAIN	4				0	0
170	04512-50080	WASHER SPRING	4				0.001	0.0022
180	04811-00200	O RING	2				0.001	0.0022
190	06312-10020	PLUG	1				0.015	0.033

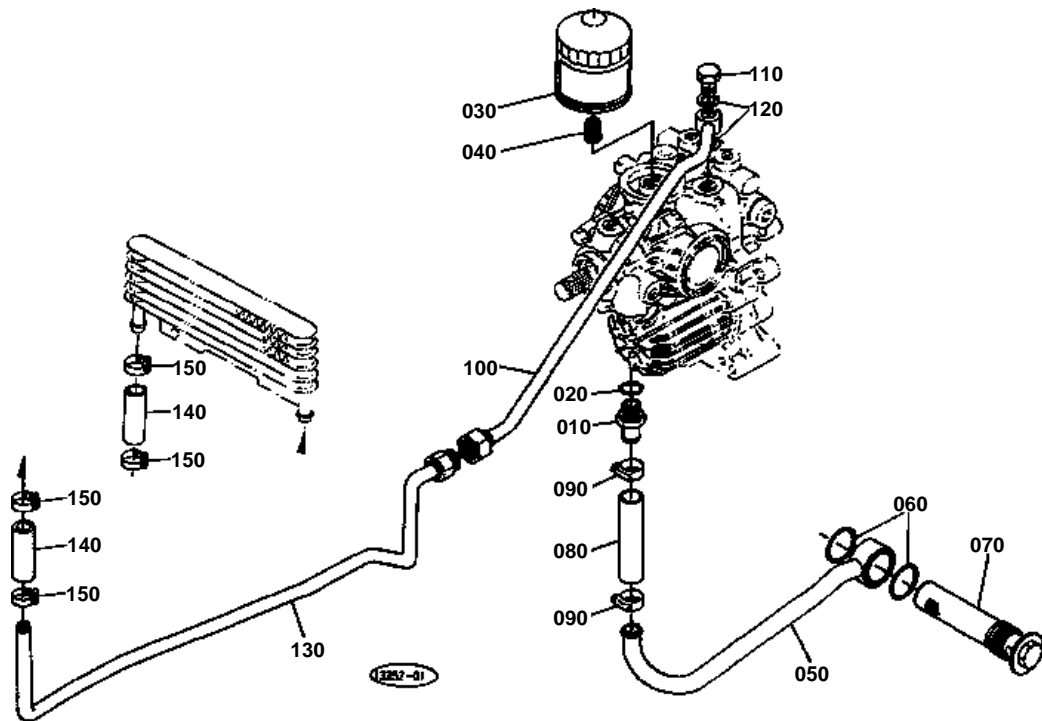



↔ Interchangeable; ≠ not interchangeable; ← new for old; → old for new

REF.No	Part No.	Description	Q'ty	S.No.	I/C	REMARKS	Weight (kgf)	Weight (lb)
010	66204-36150	JOINT INLET	1				0.07	0.154
020	04811-00180	O RING	1				0.001	0.0022
030	66021-36060	CARTRIDGE OIL FILTER	1				0.34	0.748
040	66204-36170	JOINT FILTER	1				0.018	0.0396
050	66204-36192	PIPE INLET	1				0.34	0.748
060	04811-06400	O RING	2				0.001	0.0022
070	66204-36210	FILTER OIL	1				0.367	0.8074
080	66204-36220	HOSE	1				0.07	0.154
090	66204-36230	BAND PIPE	2				0.02	0.044
100	66204-36240	PIPE SUCTION	1				0.35	0.77
110	66591-36250	JOINT	1				0.08	0.176
120	67111-37180	GASKET	2				0.003	0.0066
130	66204-36260	PIPE SUCTION	1				0.6	1.32
140	66204-36270	HOSE	2				0.038	0.0836
150	66204-36280	BAND PIPE	4				0.02	0.044

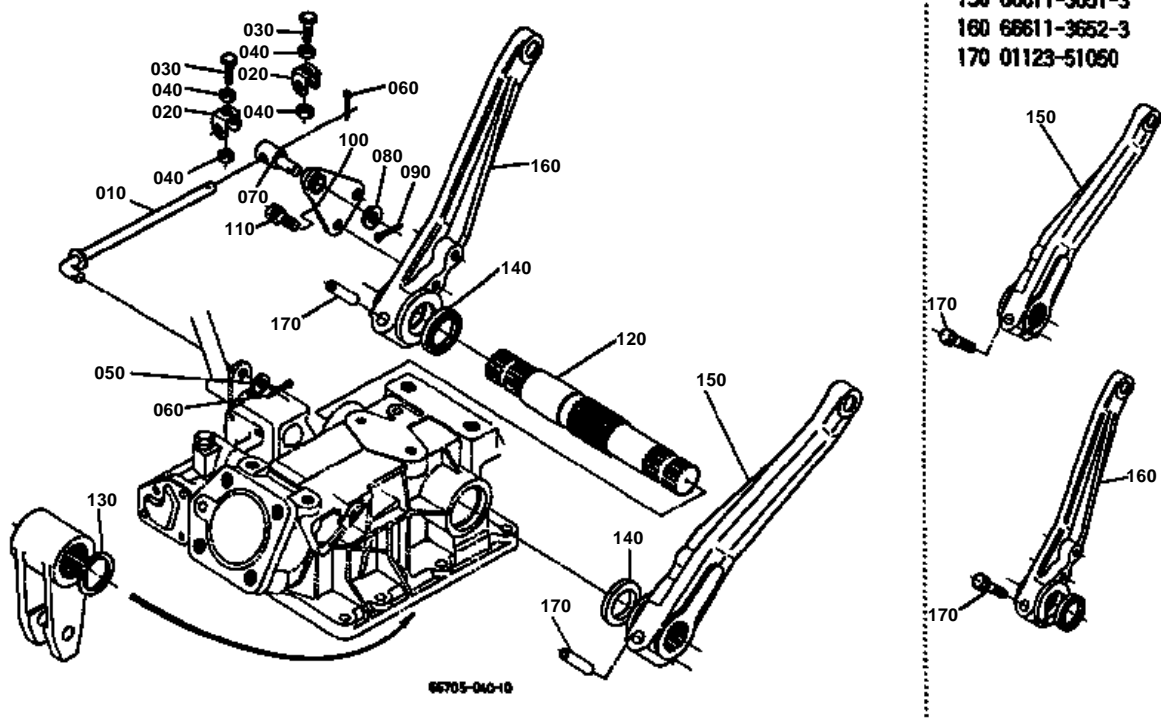



↔ Interchangeable; ≠ not interchangeable; ← new for old; → old for new

REF.No	Part No.	Description	Q'ty	S.No.	I/C	REMARKS	Weight (kgf)	Weight (lb)
010	66704-36310	ROD INTERLOCKER	1				0.075	0.165
020	66611-36320	INTERLOCKER	2				0.022	0.0484
030	01153-50822	BOLT	2				0.011	0.0242
040	02112-50080	NUT	4				0.003	0.0066
050	04012-50080	WASHER PLAIN	1				0.001	0.0022
060	05511-50215	PIN SPLIT	2				0.001	0.0022
070	66591-36540	SHAFT LOCK	1				0.034	0.0748
080	04011-50100	WASHER PLAIN	1				0.002	0.0044
090	05511-50318	PIN SPLIT	1				0.001	0.0022
100	66591-36550	SUPPORT INTERLOCKER	1				0.072	0.1584
110	01123-50822	BOLT	2				0.012	0.0264
120	66591-36694	SHAFT HYD.ARM	1	≤63788			0	0
120	66591-36695	SHAFT HYD.ARM	1	≥63789	←		1.15	2.53
130	04612-00320	CIR CLIP EXTERNAL	1				0.004	0.0088
140	09230-28405	SEAL OIL	2				0.006	0.0132
150	66611-36513	ARM LIFT LH	1	≤63788			1.5	3.3
150	66611-36514	ARM LIFT LH	1	≥63789	←		1.47	3.234
160	66611-36523	ARM LIFT RH	1	≤63788			1.45	3.19
160	66611-36524	ARM LIFT RH	1	≥63789	←		1.42	3.124
170	01123-51050	BOLT	2	≤63788			0.035	0.077
170	05411-01050	PIN SPRING	2	≥63789	←		0.019	0.0418

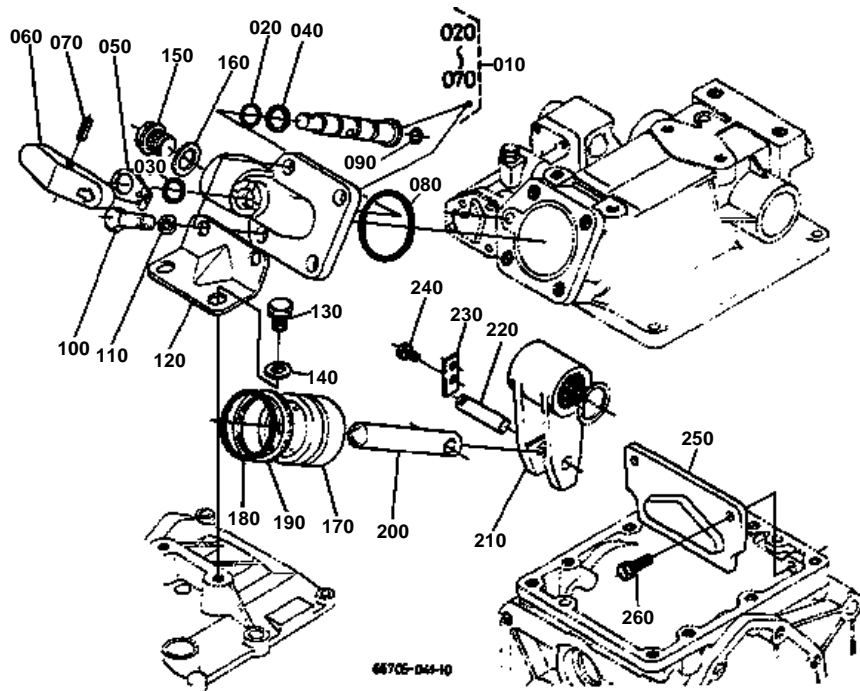



↔ Interchangeable; ≠ not interchangeable; ← new for old; → old for new

REF.No	Part No.	Description	Q'ty	S.No.	I/C	REMARKS	Weight (kgf)	Weight (lb)
010	66404-36600	ASSY CAP CYLINDER	1				1.17	2.574
020	04811-00120	O RING	1				0.001	0.0022
030	04811-00160	O RING	1				0.001	0.0022
040	96319-01430	WASHER THRUST	1				0.002	0.0044
050	96319-01440	SPRING	1				0.002	0.0044
060	96319-01450	KNOB	1				0.04	0.088
070	05411-00520	PIN SPRING	1				0.002	0.0044
080	04810-50550	O RING	1				0.002	0.0044
090	04810-05110	O RING	1				0.001	0.0022
100	66711-36440	BOLT	4				0.045	0.099
110	04512-50120	WASHER SPRING	4				0.003	0.0066
120	66611-36413	STAY	1				0.14	0.308
130	01123-51025	BOLT	2				0.02	0.044
140	04013-50100	WASHER PLAIN	2				0	0
150	06311-25040	PLUG	1				0.09	0.198
160	66611-36420	GASKET	1				0.006	0.0132
170	67211-36410	PISTON HYD.	1				0.55	1.21
180	04810-08500	O RING	1				0.005	0.011
190	67211-36420	RING BACK UP	1				0.003	0.0066
200	66591-36640	ROD HYD.PISTON	1				0.31	0.682
210	66591-36650	ARM HYDRAULIC	1				0.8	1.76
220	66591-36660	PIN ARM	1				0.045	0.099
230	66591-36670	STOPPER	1				0.01	0.022
240	01202-50614	BOLT	2				0.006	0.0132
250	66621-36750	PLATE HYD.ARM	1				0.34	0.748
260	67211-36610	BOLT	2				0.015	0.033

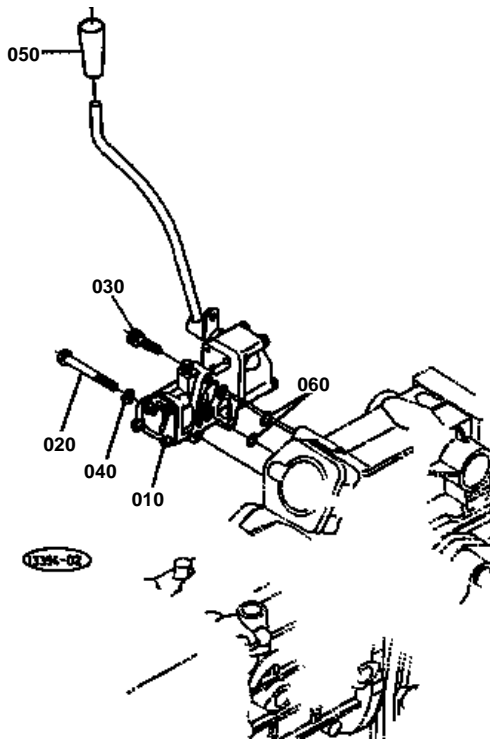



↔ Interchangeable; ≠ not interchangeable; ← new for old; → old for new

REF.No	Part No.	Description	Q'ty	S.No.	I/C	REMARKS	Weight (kgf)	Weight (lb)
010	66711-36200	ASSY VALVE CONTROL	1			REFER TO L.No.0D15-R0 FOR COMPONENT PART	2.665	5.863
020	01153-50875	BOLT	2				0.028	0.0616
030	01123-50845	BOLT	1				0.02	0.044
040	04512-50080	WASHER SPRING	2				0.001	0.0022
050	54201-23270	GRIP	1				0.02	0.044
060	04810-00120	O RING	2				0.001	0.0022

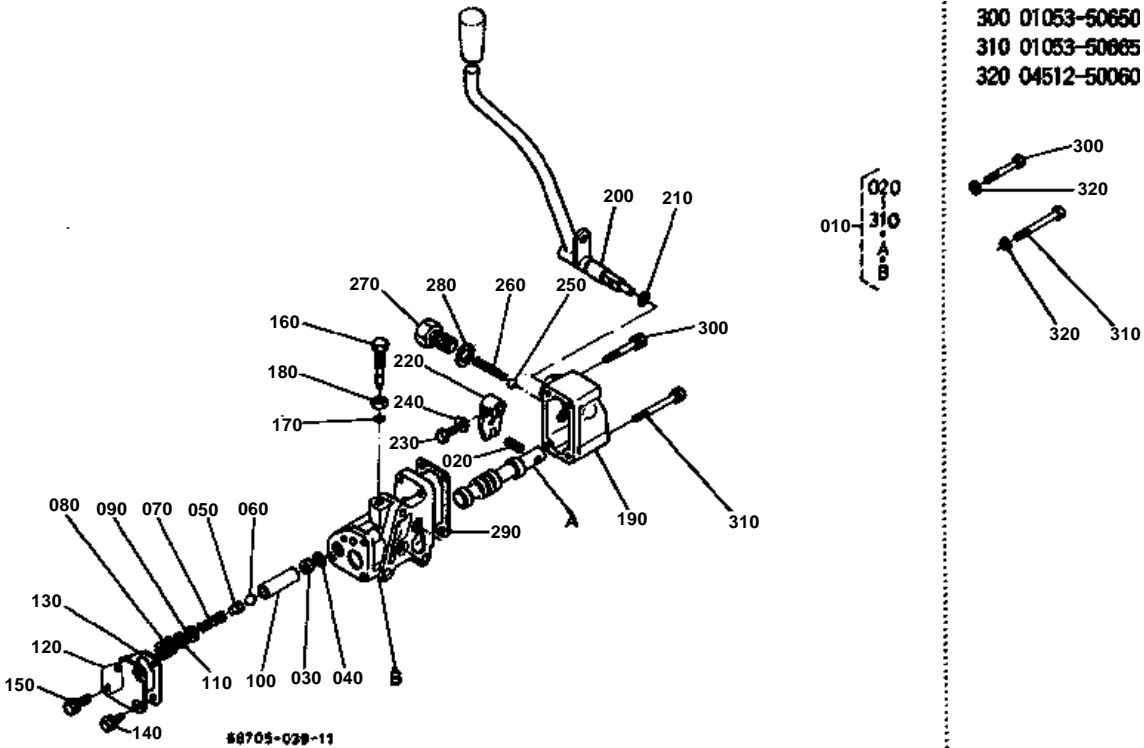



**CONTROL VALVE [COMPONENT PARTS] TRACTOR S.No.:B7100HST-D >=60164
B7100HST-E >=20025**

↔ Interchangeable; ≠ not interchangeable; ← new for old; → old for new

REF.No	Part No.	Description	Q'ty	S.No.	I/C	REMARKS	Weight (kgf)	Weight (lb)
010	66711-36200	ASSY VALVE CONTROL	1				2.665	5.863
020	05411-00620	PIN SPRING	1				0.002	0.0044
030	66591-36330	SEAT VALVE	1				0.008	0.0176
040	04811-15120	O RING	1				0.001	0.0022
050	66611-36222	STOPPER SPRING	1				0.008	0.0176
060	07715-03211	BALL	1				0.003	0.0066
070	66591-36350	SPRING	1				0.01	0.022
080	66591-36360	SCREW ADJUSTING	1				0.012	0.0264
090	04012-50060	WASHER PLAIN	1				0.001	0.0022
100	66591-36370	COLLAR	1				0.016	0.0352
110	66611-36330	SHIM ADJUSTING	1				0.001	0.0022
120	66611-36260	COVER RELIEF	1				0.03	0.066
130	66591-36390	GASKET	1				0	0
140	01202-50618	BOLT	2				0.006	0.0132
150	01202-50622	BOLT	2				0.007	0.0154
160	66591-36413	BOLT ADJUSTING	1				0.028	0.0616
170	04811-10040	O RING	1				0.001	0.0022
180	02112-50100	NUT	1				0.004	0.0088
190	66591-36430	COVER VALVE	1				0.18	0.396
200	66711-36250	LEVER CONTROL	1				0.392	0.8624
210	04811-00100	O RING	1				0.001	0.0022
220	66591-36450	ARM VALVE GUIDE	1				0.05	0.11
230	66591-36480	BOLT	1				0.004	0.0088
240	04111-50060	WASHER	1				0.001	0.0022
250	07715-00803	BALL	1				0.004	0.0088
260	62061-18270	SPRING STOPPER	1				0.003	0.0066
270	66591-36460	BOLT	1				0.054	0.1188
280	04714-00300	GASKET	1				0.002	0.0044
290	66591-36470	GASKET	1				0	0
300	01053-50650	BOLT	2	≤71245			0.011	0.0242
300	01202-50650	BOLT	2	≥71246	↔		0	0
310	01053-50665	BOLT	2	≤71245			0.015	0.033
310	01202-50665	BOLT	2	≥71246	↔		0.02	0.044
320	04512-50060	WASHER SPRING	4	≤71245			0	0

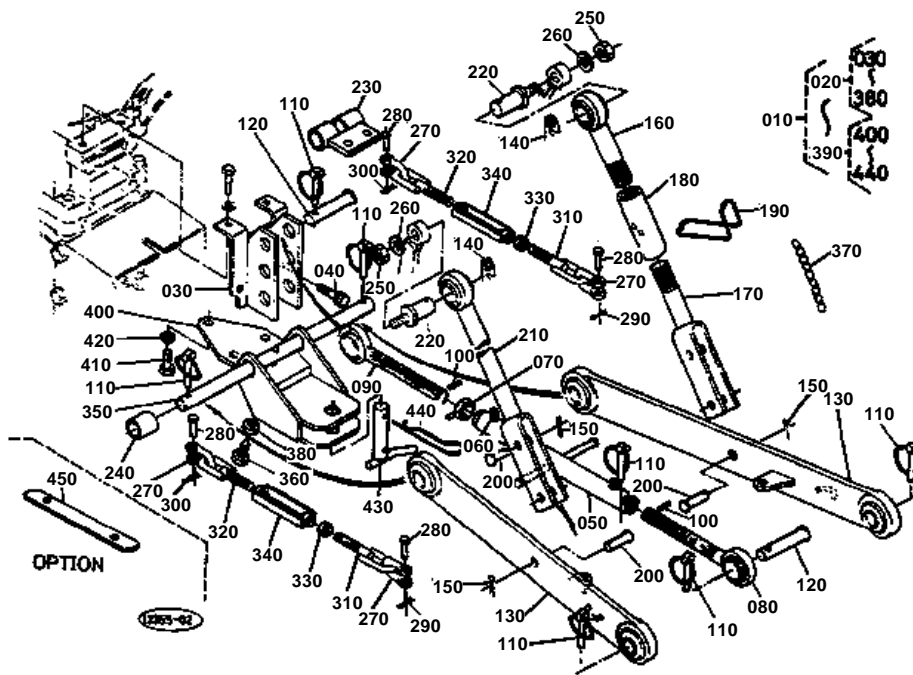

430 66204-6561-0

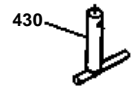



3-POINT LINKAGE TRACTOR S.No.:B7100HST-D >=60164 B7100HST-E >=20025

↔ Interchangeable; ≠ not interchangeable; ← new for old; → old for new

REF.No	Part No.	Description	Q'ty	S.No.	I/C	REMARKS	Weight (kgf)	Weight (lb)
010	66204-65100	ASSY 3-POINT LINKAGE	1				28	61.6
020	66204-65200	ASSY ROD 3-POINT	1				22	48.4
030	96316-06110	BRACKET TOP LINK	1				1.22	2.684
040	01123-51230	BOLT	2				0.04	0.088
050	66706-65332	LINK TOP	1				1	2.2
060	67211-42940	NIPPLE GREASE	2				0.001	0.0022
070	66706-65340	NUT TOP LINK	1				0.05	0.11
080	66706-65352	JOINT TOP LINK LH	1				0.73	1.606
090	66706-65362	JOINT TOP LINK RH	1				0.77	1.694
100	05411-00422	PIN SPRING	2				0.001	0.0022
110	34150-37640	PIN SET	7				0.06	0.132
120	31150-71360	PIN JOINT	2				0.166	0.3652
130	67401-65213	COMP.LINK LOWER	2				5.34	11.748
140	66713-34340	PIN SET	2				0.013	0.0286
150	05511-50425	PIN SPLIT	3				0.003	0.0066
160	66706-65232	ROD LIFT RH	1				0.315	0.693
170	66706-65240	ROD LIFT LOWER RH	1				0.5	1.1
180	66706-65250	NUT	1				0	0
190	66706-65260	SPRING	1				0.041	0.0902
200	05122-51240	PIN JOINT	3				0.039	0.0858
210	66706-65272	COMP.ROD LIFT LH	1				0.9	1.98
220	66706-65280	PIN LIFT	2				0.082	0.1804
230	67401-65290	BRACKET CHECK CHAIN	1				0.63	1.386
240	66204-65350	SPACER	2				0.12	0.264
250	02174-50120	NUT	2				0.01	0.022
260	04512-50120	WASHER SPRING	2				0.003	0.0066
270	67401-65370	JOINT CHAIN	4				0.1	0.22
280	66706-65380	PIN SET	4				0.021	0.0462
290	05511-50318	PIN SPLIT	2				0.001	0.0022
300	05515-51000	PIN SNAP	2				0	0
310	66706-65310	BOLT TURNBUCKLE RH	2				0.153	0.3366
320	66706-65320	BOLT TURNBUCKLE LH	2				0.153	0.3366
330	02112-50120	NUT	2				0.007	0.0154
340	96316-05580	TURNBUCKLE	2				0.14	0.308
350	66704-86110	PIN LOWER LINK	1				1.19	2.618
360	66204-65120	BOLT SET	1				0.055	0.121
370	66616-34550	CHAIN	1				0.66	1.452
380	02174-50140	NUT	1				0.014	0.0308
390	66204-65502	ASSY HITCH	1				3.6	7.92
400	66204-65606	COMP.HITCH	1				3.59	7.898
410	01153-51235	BOLT	3				0.039	0.0858
420	04512-50120	WASHER SPRING	3				0.003	0.0066
430	66204-65610	PIN HITCH	1	<=63885			0	0
430	67800-29320	PIN HITCH	1	>=63886	↔		0.2	0.44
440	31150-29730	PIN SPRING	1				0.044	0.0968
450	66204-86510	DRAWBAR	1			OPTION	3.06	6.732

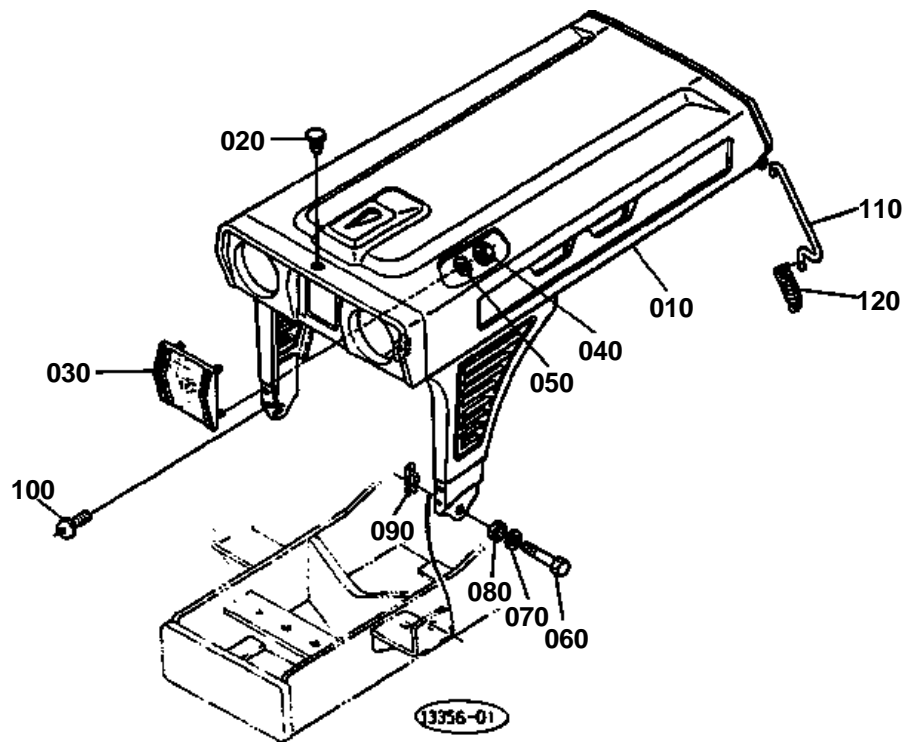



↔ Interchangeable; ≠ not interchangeable; ← new for old; → old for new

REF.No	Part No.	Description	Q'ty	S.No.	I/C	REMARKS	Weight (kgf)	Weight (lb)
010	66732-54110	BONNET	1				9	19.8
020	63763-52580	RUBBER HANDLE COVER	1				0.001	0.0022
030	66711-54140	MASCOT	1				0.09	0.198
040	02014-50060	NUT	4				0.003	0.0066
050	04512-50060	WASHER SPRING	4				0	0
060	66711-54150	BOLT	2				0.026	0.0572
070	04015-50100	WASHER PLAIN	2				0.016	0.0352
080	34150-18180	CUSHION	2				0.003	0.0066
090	05515-51000	PIN SNAP	2				0	0
100	03004-50812	SCREW WITH WASHER	4				0.008	0.0176
110	66751-55210	HOOK BONNET	2				0.04	0.088
120	66711-55220	SPRING	2				0.01	0.022

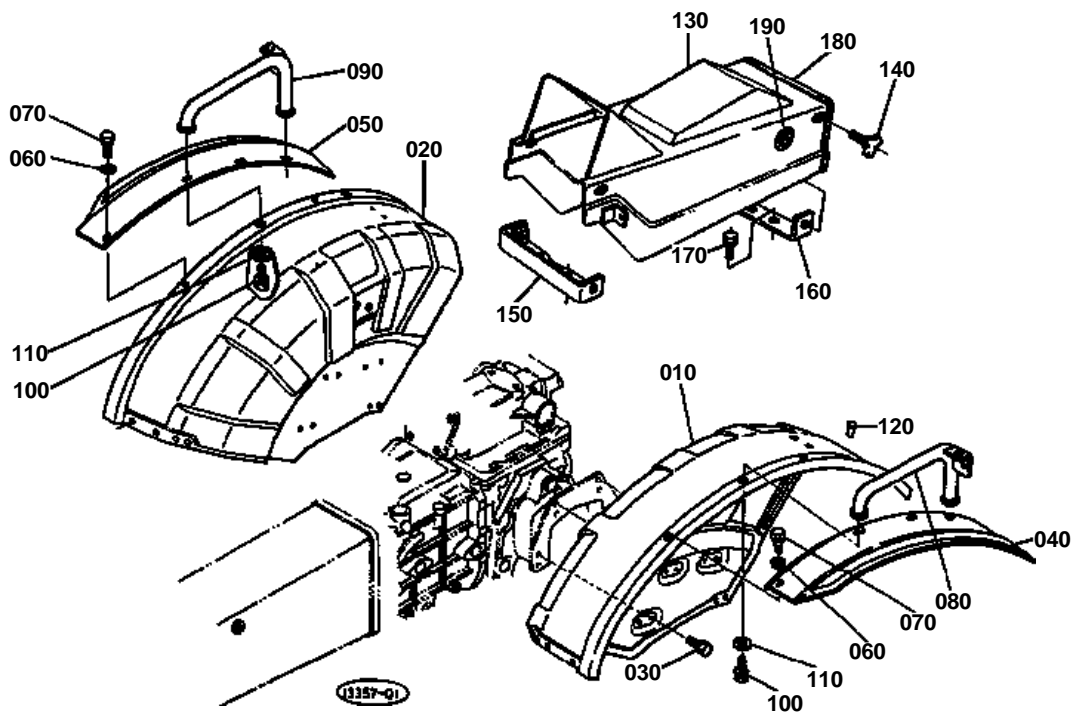



↔ Interchangeable; ≠ not interchangeable; ← new for old; → old for new

REF.No	Part No.	Description	Q'ty	S.No.	I/C	REMARKS	Weight (kgf)	Weight (lb)
010	66727-52710	FENDER LH	1				5.5	12.1
020	66727-52720	FENDER RH	1				5.5	12.1
030	01123-50818	BOLT	8				0.012	0.0264
040	66612-52730	FENDER EXTENSION LH	1				0.53	1.166
050	66612-52740	FENDER EXTENSION RH	1				0.53	1.166
060	04013-50060	WASHER PLAIN	6				0	0
070	01202-50614	BOLT	6				0.006	0.0132
080	66612-52750	RAIL LH	1				0.24	0.528
090	66612-52760	RAIL RH	1				0.24	0.528
100	01123-50820	BOLT	4				0.011	0.0242
110	04013-50080	WASHER PLAIN	4				0	0
120	38240-29570	PLUG	6				0.001	0.0022
130	66204-53110	COVER SUB	1				1.95	4.29
140	01820-50615	BOLT KNOB	4				0.017	0.0374
150	66204-53130	STAY FRONT	1				0.165	0.363
160	66204-53140	STAY REAR	1				0.09	0.198
170	01123-50820	BOLT	2				0.011	0.0242
180	66204-53150	TRIM SASH	1				0.02	0.044
190	66204-47140	LABEL	1				0.001	0.0022

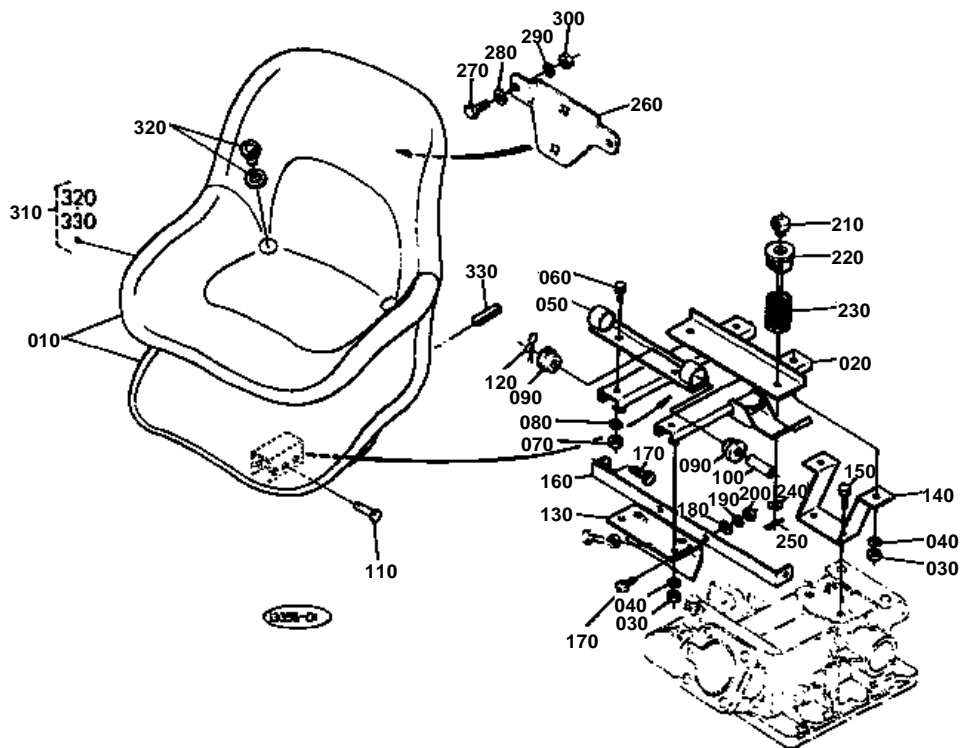



↔ Interchangeable; ≠ not interchangeable; ← new for old; → old for new

REF.No	Part No.	Description	Q'ty	S.No.	I/C	REMARKS	Weight (kgf)	Weight (lb)
010	66732-45900	ASSY SEAT	1				5.5	12.1
020	66204-45930	ADJUSTER SEAT	1				2.1	4.62
030	02118-50100	NUT	4				0.005	0.011
040	04512-50100	WASHER SPRING	4				0	0
050	66204-45940	SUPPORT SEAT FRONT	1				0.29	0.638
060	01153-50814	BOLT	2				0.009	0.0198
070	02114-50080	NUT	2				0.005	0.011
080	04512-50080	WASHER SPRING	2				0.001	0.0022
090	66591-41540	CUSHION	4				0.01	0.022
100	66591-41550	COLLAR	2				0.02	0.044
110	05122-51045	PIN JOINT	2				0	0
120	05516-51000	PIN SNAP	2				0	0
130	66204-45950	SUPPORT ADJUSTER	1				0	0
140	66204-45962	SUPPORT ADJUSTER	1				0.22	0.484
150	01123-50825	BOLT	2				0.013	0.0286
160	66204-45993	STAY FENDER	1				0.2	0.44
170	01153-50820	BOLT	4				0.012	0.0264
180	04013-50080	WASHER PLAIN	2				0	0
190	04512-50080	WASHER SPRING	4				0.001	0.0022
200	02114-50080	NUT	2				0.005	0.011
210	32160-18440	CUSHION	2				0.013	0.0286
220	66204-45970	RETAINER SPRING	2				0.1	0.22
230	66204-45980	SPRING SEAT	2				0.1	0.22
240	04012-50080	WASHER PLAIN	2				0.001	0.0022
250	05511-50215	PIN SPLIT	2				0.001	0.0022
260	66704-54952	BRACKET SMV	1				0.15	0.33
270	01053-50616	BOLT	2				0.005	0.011
280	04013-50060	WASHER PLAIN	2				0	0
290	04512-50060	WASHER SPRING	2				0	0
300	02014-50060	NUT	2				0.003	0.0066
310	66704-83500	ASSY COVER SEAT	1				0.4	0.88
320	35110-85050	EYELET	4				0.005	0.011
330	35110-85060	PROTECTOR	3				0.01	0.022

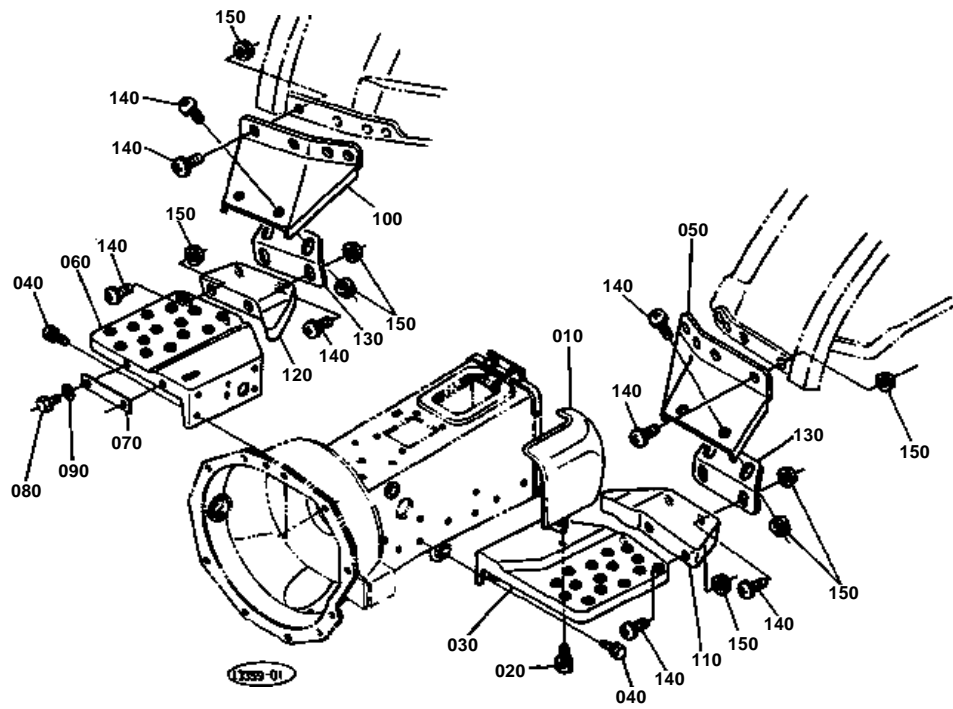



↔ Interchangeable; ≠ not interchangeable; ← new for old; → old for new

REF.No	Part No.	Description	Q'ty	S.No.	I/C	REMARKS	Weight (kgf)	Weight (lb)
010	66204-82610	COVER FOOT	1				0.25	0.55
020	01123-50814	BOLT	2				0	0
030	66711-51130	STEP LH	1				2.078	4.5716
040	01123-50818	BOLT	10				0.012	0.0264
050	66732-51150	PLATE SUB LH	1				0.13	0.286
060	66204-51140	STEP RH	1				1.85	4.07
070	66711-51180	PLATE FEEDING ADJ	1				0.045	0.099
080	01123-50818	BOLT	2				0.012	0.0264
090	04013-50080	WASHER PLAIN	2				0	0
100	66732-51160	PLATE SUB RH	1				0.135	0.297
110	66204-51050	STEP AID LH	1				0.233	0.5126
120	66204-51060	STEP AID RH	1				0.23	0.506
130	66732-51170	STAY	2				0.04	0.088
140	66704-51150	SCREW WITH WASHER	20				0.01	0.022
150	02751-50060	NUT FLANGE	20				0.005	0.011

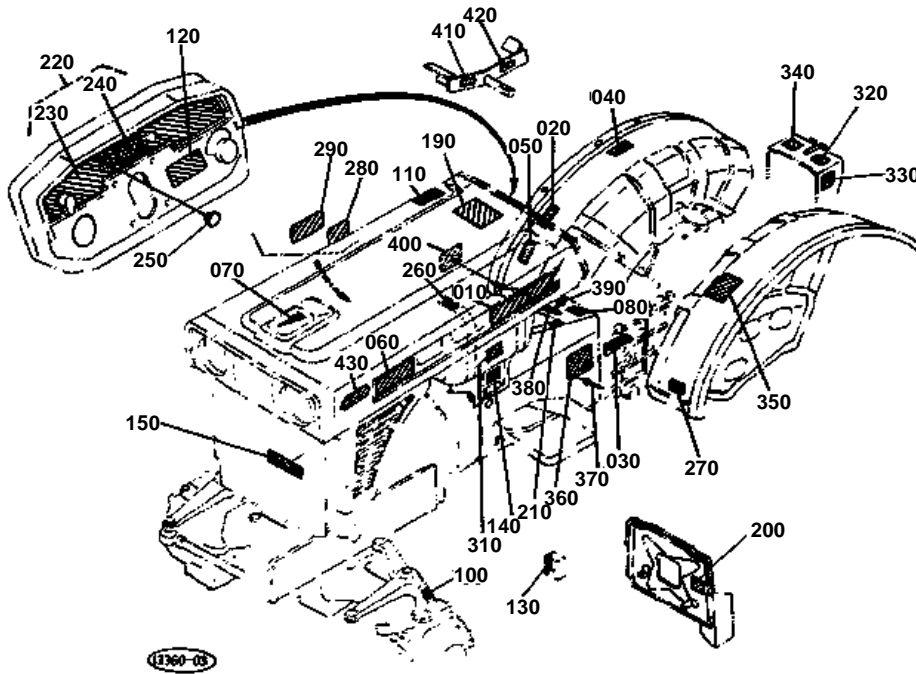

090 66204-4721-3
100 66204-4722-0

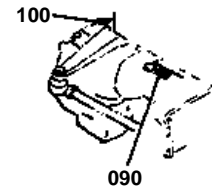



LABEL 2 TRACTOR S.No.:B7100HST-D >=60164 B7100HST-E >=20025

↔ Interchangeable; ≠ not interchangeable; ← new for old; → old for new

REF.No	Part No.	Description	Q'ty	S.No.	I/C	REMARKS	Weight (kgf)	Weight (lb)
010	66621-47100	LABEL KUBOTA	2				0.001	0.0022
020	66427-47120	LABEL HI-LO SHIFT	1				0.001	0.0022
030	66204-47133	LABEL	1				0.001	0.0022
040	66426-47140	LABEL LIFT	1				0.002	0.0044
050	66426-47150	LABEL 4WD	1				0.005	0.011
060	66204-47180	LABEL B7100HST	2				0.002	0.0044
070	66591-47190	LABEL	1				0.001	0.0022
080	66204-47190	LABEL OIL FILLER	1				0.001	0.0022
090	66204-47213	LABEL OIL	1	<=64107			0.001	0.0022
100	66204-47220	LABEL OIL	2	<=64107			0.001	0.0022
110	66204-47230	LABEL RELEASE	1				0.001	0.0022
120	66706-47240	LABEL GLOW PLUG	1				0.001	0.0022
130	66706-47250	NAME PLATE SPACER	1				0.001	0.0022
140	66706-47260	MARK TOOLS CASE	1				0.001	0.0022
150	K3311-47340	MARK KUBOTA	1				0.004	0.0088
160	99999-99999	BLANK	0				0	0
170	99999-99999	BLANK	0				0	0
180	99999-99999	BLANK	0				0	0
190	35260-34913	LABEL SAFETY	1			ENGLISH	0.005	0.011
190	35261-34910	LABEL SAFETY	1			FRENCH	0.006	0.0132
200	35820-98632	LABEL START CAUTION	1				0.003	0.0066
210	67061-47240	LABEL SPEED LOCK	1			ENGLISH	0.001	0.0022
210	32530-65930	LABEL START CAUTION	1			FRENCH	0.001	0.0022
220	66204-47420	LABEL PANEL	1				0	0
230	66204-47410	LABEL PANEL	1				0.02	0.044
240	66704-47440	LABEL KUBOTA	1				0.001	0.0022
250	35110-32420	PLUG	1				0.002	0.0044
260	66706-47340	LABEL CAUTION	1				0.001	0.0022
270	66427-47350	LABEL DIFF.LOCK	1	<=65015			0.001	0.0022
270	76611-47520	LABEL DIFF.LOCK	1	>=65016	↔		0.001	0.0022
280	66204-47360	LABEL PARKING BRAKE	1				0.001	0.0022
290	66204-47370	LABEL BRAKE LOCK	1				0.002	0.0044
300	99999-99999	BLANK	0				0	0
310	66706-47420	LABEL FUEL TANK	1				0.001	0.0022
320	35260-29790	LABEL DRAWBAR	1			ENGLISH	0.002	0.0044
320	35871-98660	LABEL DRAWBAR	1			FRENCH	0.001	0.0022
330	35110-21990	LABEL ONE WAY CLUTCH	1				0.001	0.0022
340	35200-25340	LABEL PTO WARNING	1			ENGLISH	0.002	0.0044
340	67840-47210	LABEL PTO	1			FRENCH	0.001	0.0022
350	35260-29782	LABEL ROPS WARNING	1			ENGLISH	0.001	0.0022
350	35871-98640	LABEL ROPS WARNING	1			FRENCH	0.002	0.0044
360	66204-47464	NAME PLATE	1				0.01	0.022
370	54102-24410	RIVET	4				0.001	0.0022
380	66204-47510	NAME PLATE	1				0.045	0.099
390	03004-50610	SCREW WITH WASHER	4				0.004	0.0088
400	66427-47520	LABEL MAIN SHIFT	1				0.005	0.011
410	66427-47530	LABEL FORWARD	1				0.001	0.0022
420	66427-47540	LABEL REVERSE	1				0.005	0.011
430	66204-47550	MARK 4-WHEEL DRIVE	2				0.003	0.0066

IMAGE NOT AVAILABLE



↔ Interchangeable; ≠ not interchangeable; ← new for old; → old for new

REF.No	Part No.	Description	Q'ty	S.No.	I/C	REMARKS	Weight (kgf)	Weight (lb)
010	66704-61200	ASSY TOOLS	1			020 TO 150	1.8	3.96
020	66704-61210	BAG VINYL	1				0	0
030	63611-61210	BAG VINYL	1				0.01	0.022
040	07012-11012	SPANNER	1				0.041	0.0902
050	07012-11214	SPANNER	1				0.05	0.11
060	63733-61610	FEEDER OIL	1				0.02	0.044
070	10242-91410	FUNNEL	1				0.028	0.0616
080	32240-18800	SQUEEZER OIL	1				0.4	0.88
090	07013-00012	WRENCH SOCKET	1				0.136	0.2992
100	07013-50022	WRENCH SOCKET	1				0.22	0.484
110	07013-40180	HANDLE	1				0.11	0.242
120	07012-11417	SPANNER	1				0.084	0.1848
130	07012-12126	SPANNER	1				0.244	0.5368
140	07211-10150	PLIERS	1				0.16	0.352
150	07012-11922	SPANNER	1				0.2	0.44
160	15241-86612	WRENCH FILTER	1				0.115	0.253
170	66021-36060	CARTRIDGE OIL FILTER	1				0.34	0.748
180	66204-62990	MANUAL INSTRUCTION	1			[A] [CA] (ENGLISH)	0.174	0.3828
180	66204-99010	MANUAL INSTRUCTION	1			[CA] (FRENCH)	0	0
180	66204-62950	MANUAL INSTRUCTION	1			[AU]	0.17	0.374